

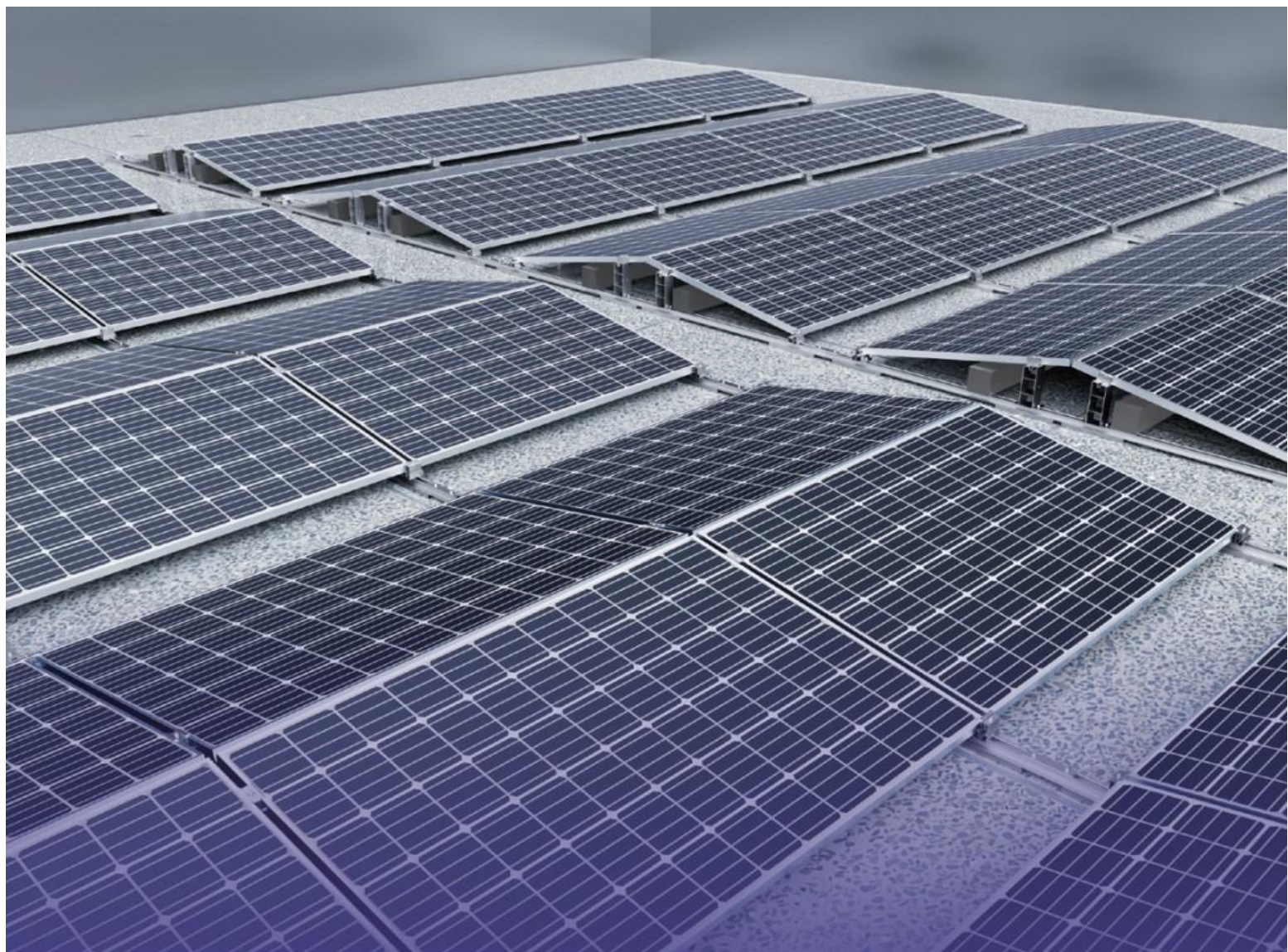

Xiamen Wintop New Energy Tech. Co., Ltd

---



## INSTALLATION MANUAL

-Ballast Roof Mounting System



## 1. Installation Tools



## 2. System Components

(Accessories are subject to the actual product)



Inter clamp



Bottom clamp



End clamp



EPDM rubber



Rail connector



Base rail



Rear leg



Front leg

Before installation, please check the name, quantity and specifications. to ensure that the installation requirements are met, and then install the system according to the technical drawing guidelines.

### 3. Technical Drawings

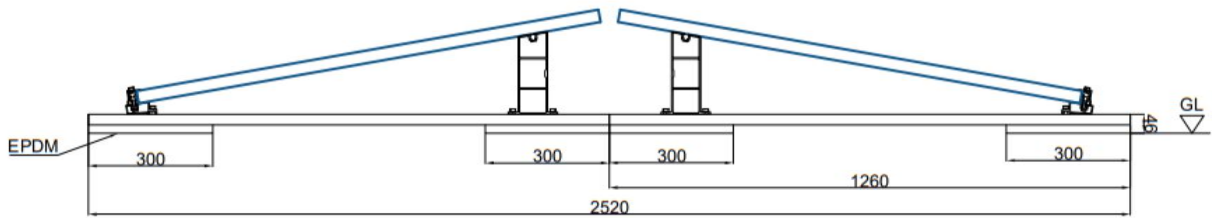

Side view (east-west orientation)

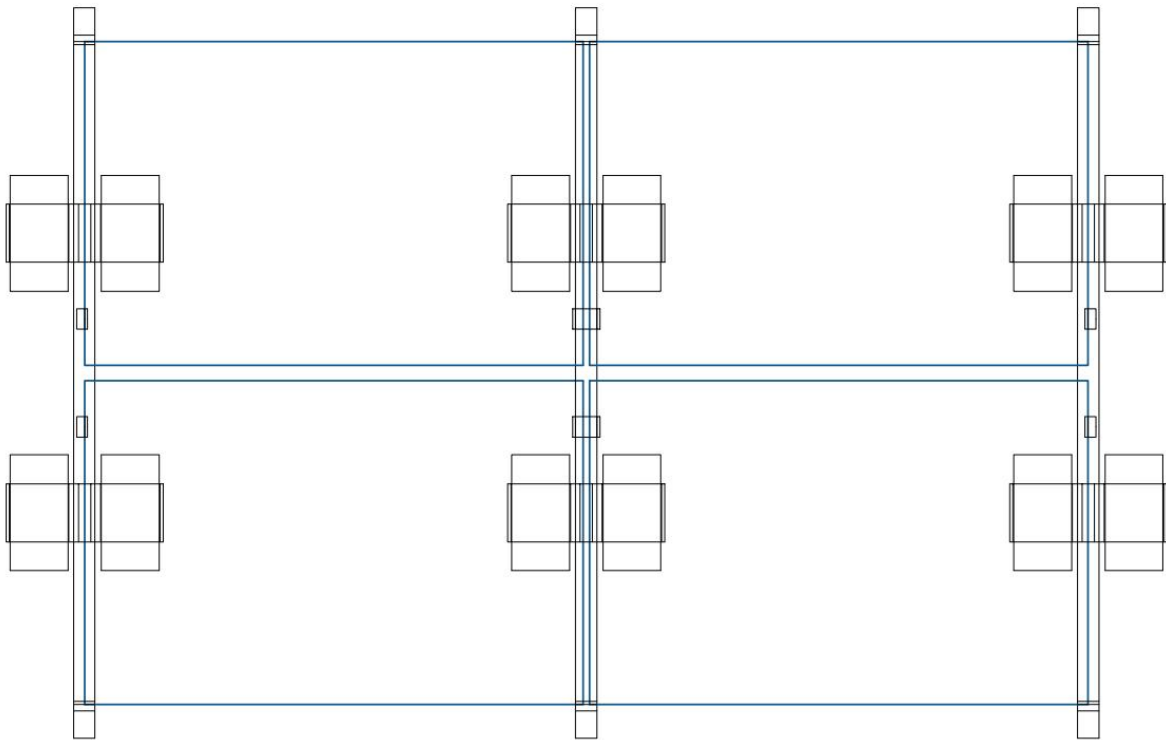

Platform view (east-west orientation)

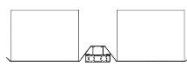

Front view (ballast pallet under blocks)

#### 4. Installation instruction

1) Slide and Insert the EPDM rubber through the bottom of base rail to assemble.



EPDM rubber



Base rail

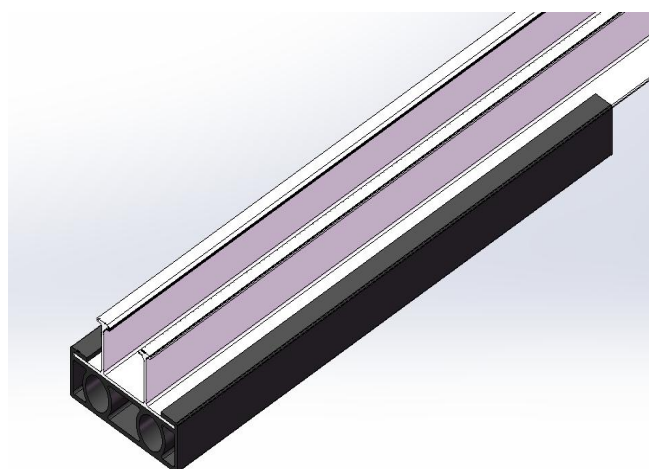

2) Connect the base rail with the rail connector (by inserting into the slot of rail) and placing them according to the positions on the drawing, lock tight the screws.



Rail connector

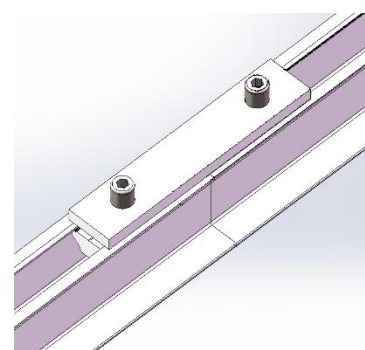
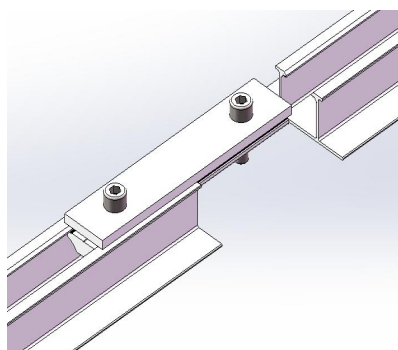

- 3) Place the base rail (connected) according to the drawings, and mark the position after placement.

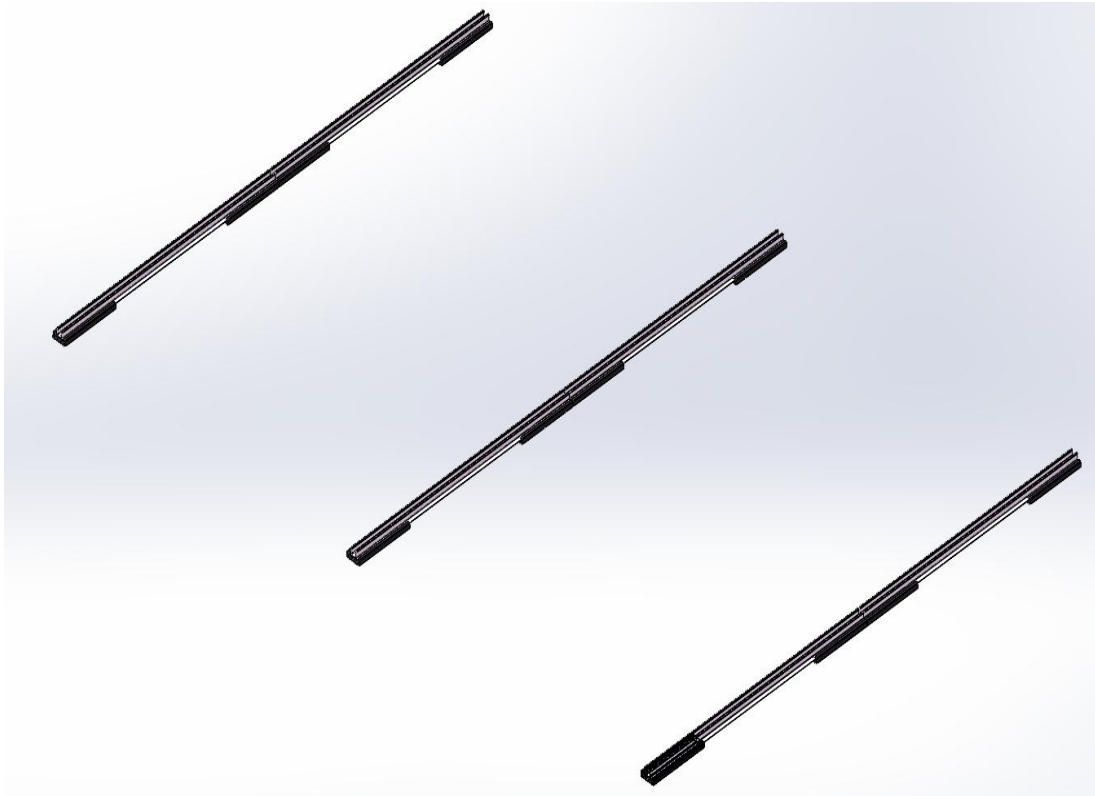

- 4) After finished the above steps, we are ready to install the front& Rear leg for the ballast system. according to the drawing, place the front leg in the right position and slide the M8\*25 bolts and nuts into the opening of base rail and lock the screw and nut tight.



Front leg

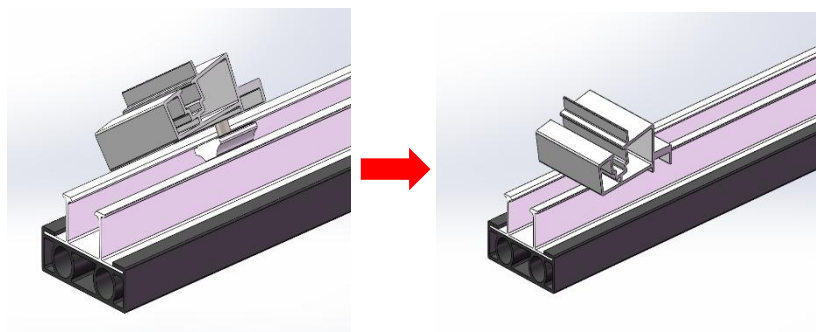

- 5) Same as the front leg, look through the drawing, and place the rear leg in the right position, and fix with two sets of M8\*25 bolts and nuts, lock tight.

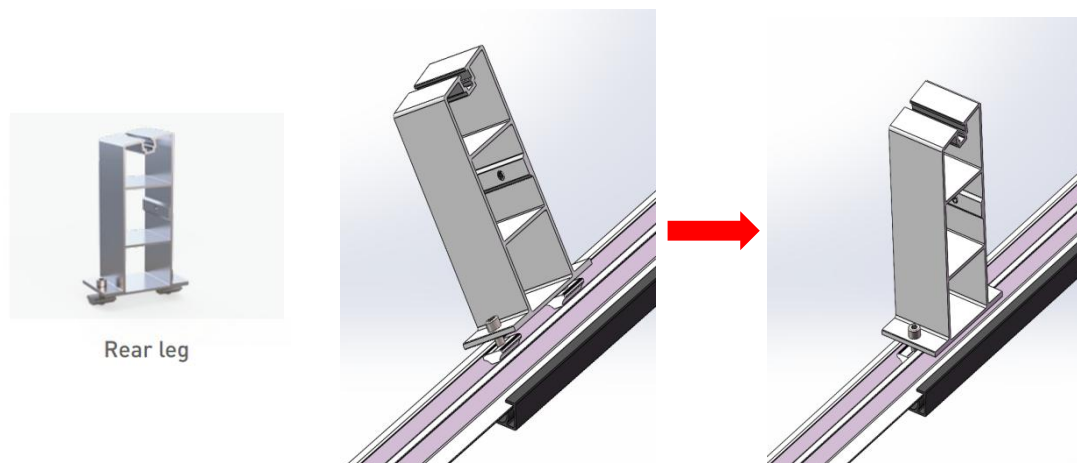

- 6) After finished the install, it should be lookd liked as below, Please make sure the structure is on the horizontal line of the same height to ensure the normal installation of solar panels.

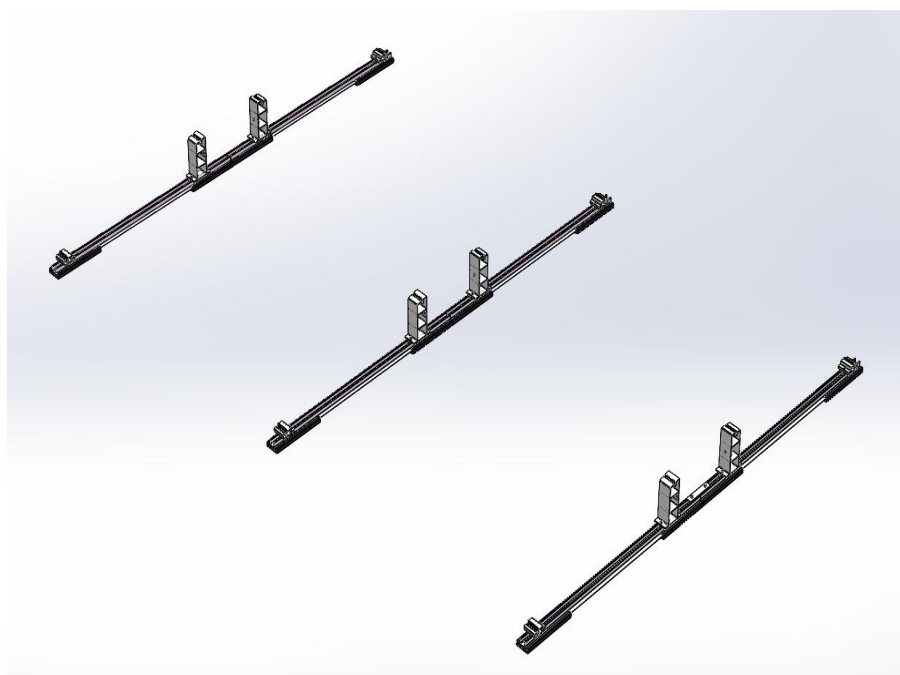

7) To install the ballast pallet, place the pallet on the base rail, put the concrete block on the pallet (pallet dimension L=200mm, W=205mm)

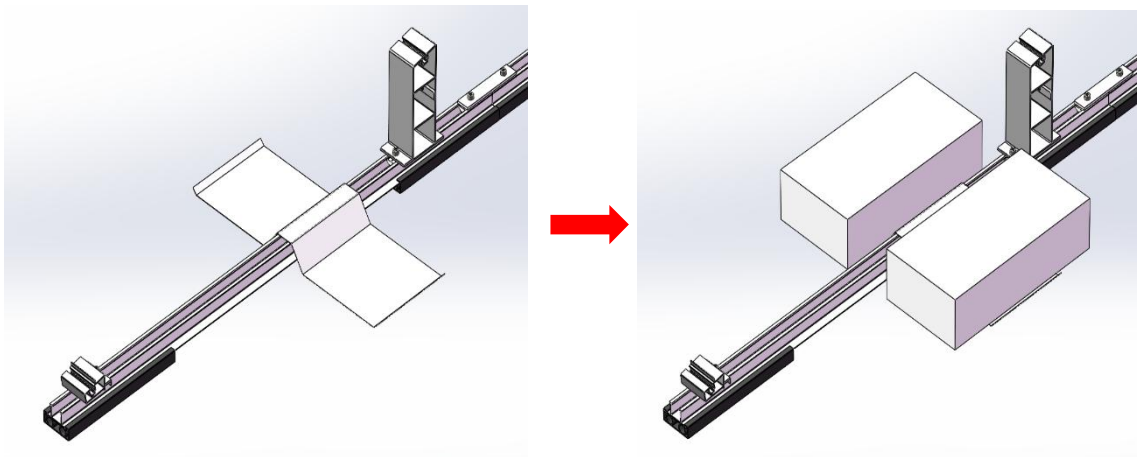

\*Drawing ref (ballast pallet)

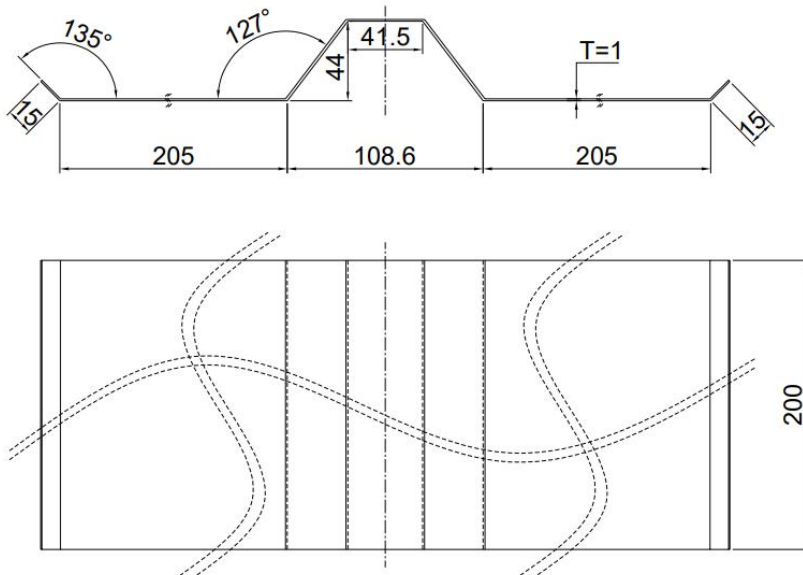

\*Designed standard weight of concrete block =9.4KG/pc,  
By wind speed 25m/s, snow loading 1kn/m<sup>2</sup>



8) After you done the install, it should've looked as below:

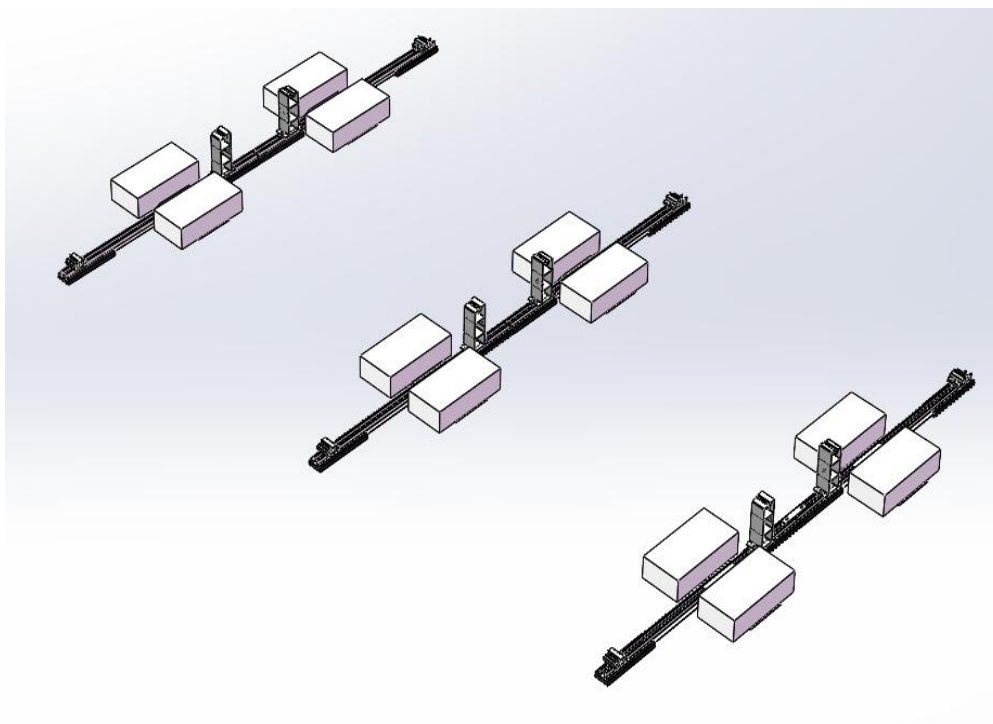

9) Place the solar panel on the slots of the front leg and the rear leg.

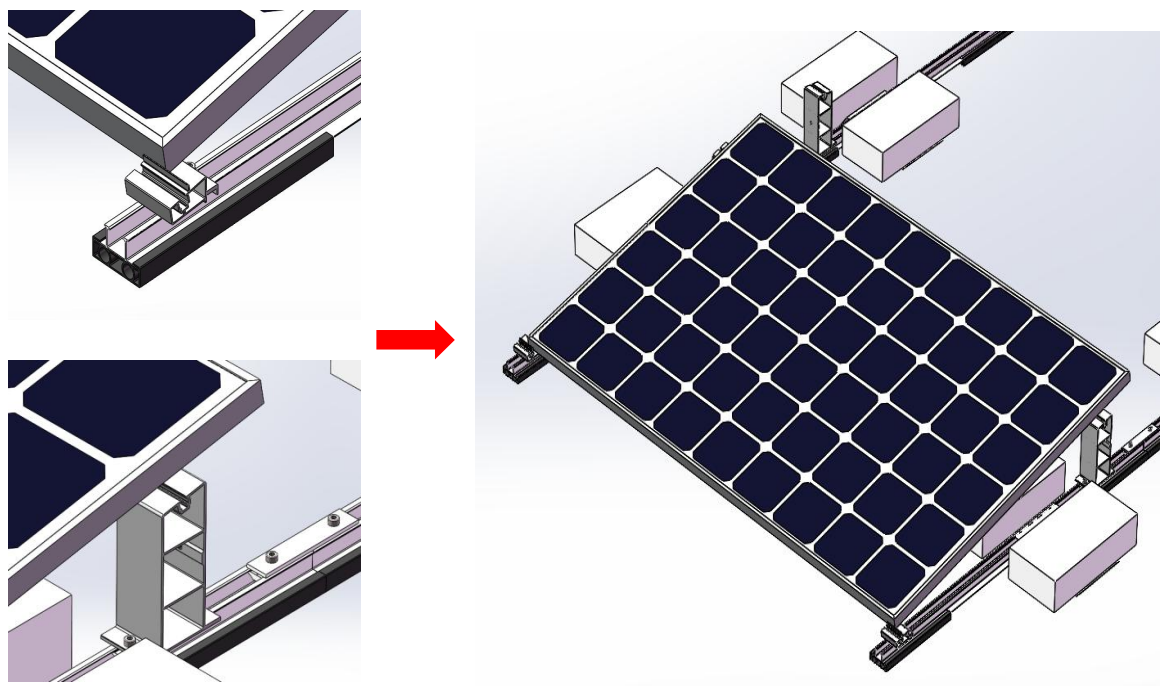

10) As shown, press the bottom clamp into the slot of front leg, lock the screw tighten the solar panel.

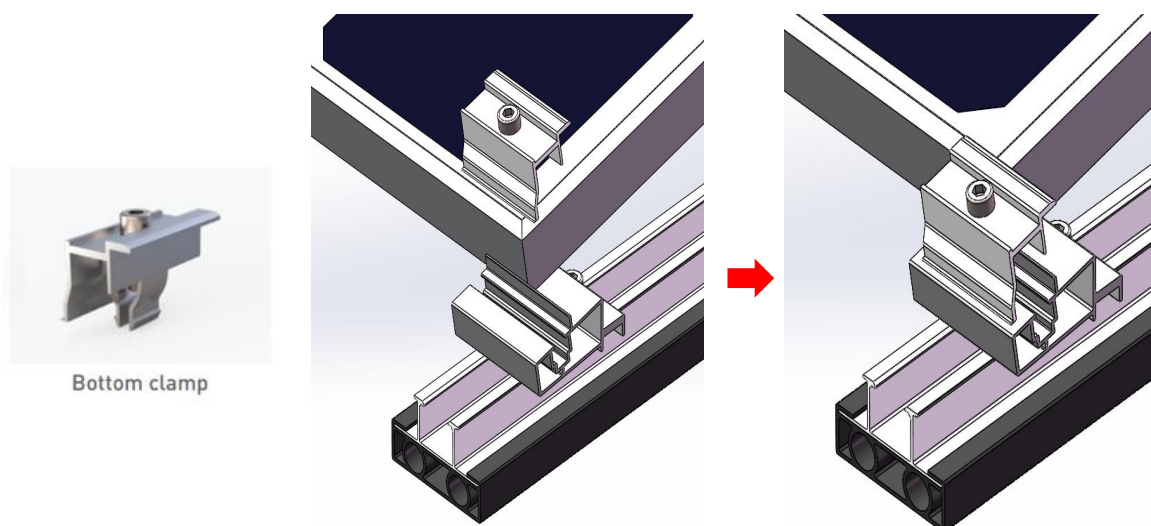

11) Same as the above step, press the bottom clamp into the slot of rear leg, lock the screw tighten the solar panel.

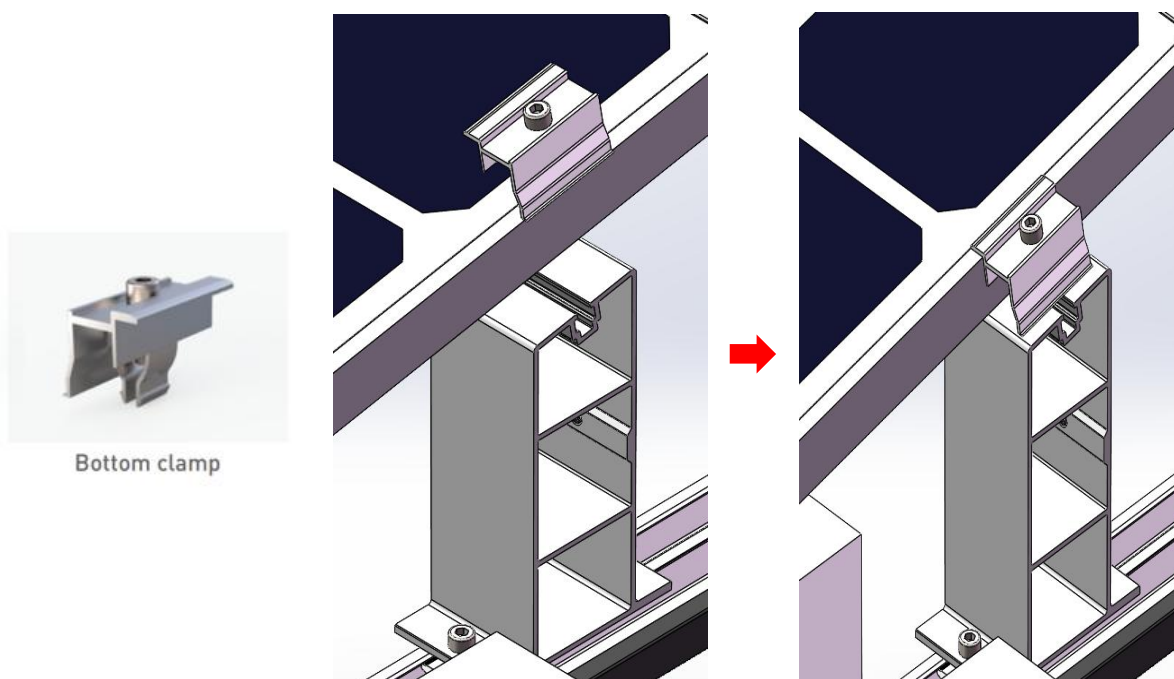

12) Press the Inter clamp into the slot of rear leg, lock the screw tighten the solar panel.



Inter clamp

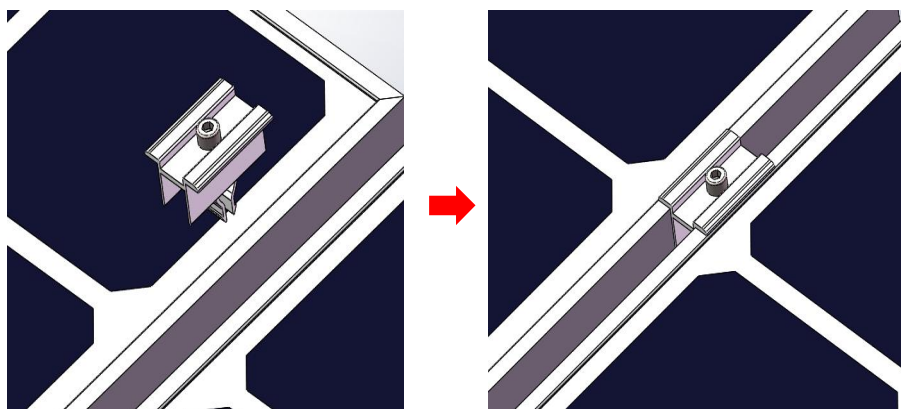

13) Install the rest of end clamp in turn, please the solar panel according to the PV layout or technical drawing, and repeat the steps of installation of end clamp on the other sides of the same row of solar panel



End clamp

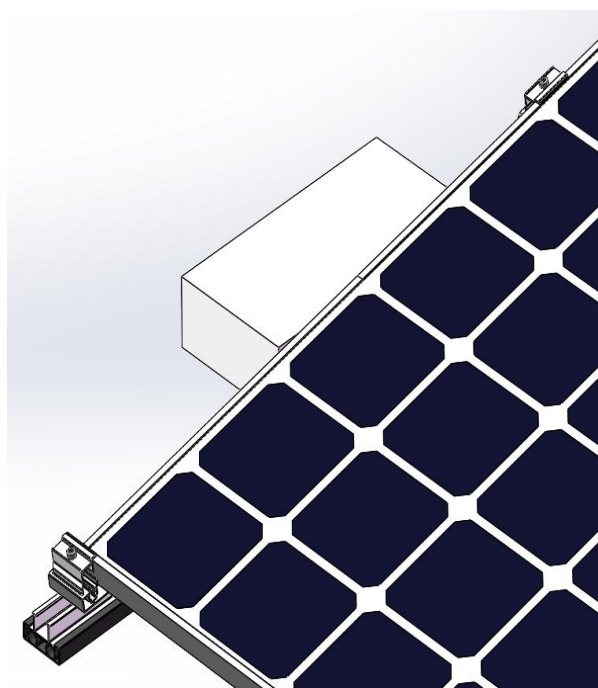

14) The installation finished should looked as below:

