

User Manual

Hybrid Inverter-Mars-10G1-LE

Hybrid Inverter-Mars-12G1-LE

Hybrid Inverter-Mars-14G1-LE

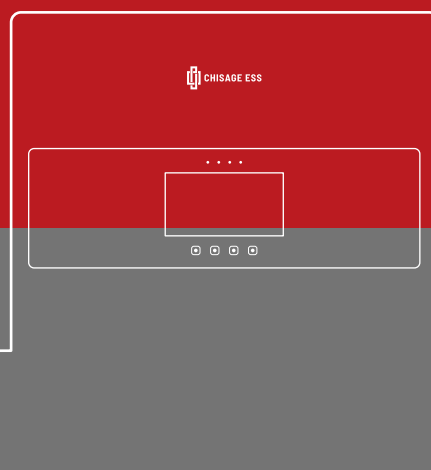

CHISAGE ESS

www.chisagess.com

Mars-10G1-LE
Mars-12G1-LE
Mars-14G1-LE
Hybrid inverter
User Manual

Contents

1 Overall introduction.....	1
1.1 Overall description.....	1
1.2 Main features and performance of functions.....	1
1.3 Product Appearance Introduction.....	2
1.4 Size introduction.....	3
1.5 System structure.....	5
1.6 Inverter parameter.....	6
2 Installation Instructions.....	7
2.1 Installation preparation.....	7
2.1.1 Installation Notes Reiterated.....	7
2.1.2 Installation environment, space requirements.....	7
2.1.3 Installation tool preparation.....	8
2.1.4 Inspection of out-of-box accessories.....	8
2.2 Introduction of equipment terminal.....	10
2.3 Wall mount.....	13
2.4 Battery wiring work.....	15
2.4.1 Battery Power Cable Wiring.....	15
2.4.2 Battery communication cable connection.....	16
2.5 Power grid, load, GEN wiring.....	16
2.6 Photovoltaic wiring.....	18
2.7 CT wiring.....	20
2.8 Ground connection.....	21
2.9 WIFI connection.....	21
2.10 Stand-alone operation and logic description.....	22
2.10.1 Stand-alone operation system diagram.....	22
2.10.2 Enter working mode to set path.....	23
2.10.3 .Sell First.....	23
2.10.4 Zero Ex To Grid Port.....	23
2.10.5 Zero Ex To CT.....	24
2.10.6 Time curve mode.....	24
2.11 Parallel operation and logical explanation.....	25
2.11.1 Set entry path description.....	25
2.11.2 Parallel operation logic.....	26
2.11.3 Parallel system wiring diagram.....	27
3 Display and setup.....	30

3.1 Run data display instructions.....	30
3.1.1 Photovoltaic data.....	33
3.1.2 Battery data.....	34
3.1.3 Inverter data.....	35
3.1.4 Grid data.....	36
3.1.5 Load data.....	37
3.2 Run parameter setting.....	37
3.2.1 Battery parameter setting.....	38
3.2.2 Grid parameter setting.....	41
3.2.3 GEN port function settings.....	41
3.2.4 CT transformation ratio setting.....	44
3.2.5 Operating Mode Settings.....	44
3.2.6 System Setup.....	45
3.3 Events Display.....	46
3.4 Device Info.....	46
4 Operation and maintenance.....	48
4.1 Trial run.....	48
4.2 Fault alarm and handling.....	48
4.3 Product routine maintenance suggestions.....	51
4.3.1 Routine inspection.....	52
4.3.2 Monthly inspection.....	52
4.3.3 Quarterly inspection.....	52
5 Product transportation and storage.....	53
5.1 Product Shipping Requirements.....	53
5.1.1 Logistics.....	53
5.1.2 Unloading and handling.....	53
5.2 Product storage environment requirements.....	53
6 Legal Notices.....	55
7 Attachments.....	56
Network port definition description.....	56
Transformer size and model.....	57
Hybrid Inverter data.....	58

Precautions

- Before using this product, please read the instruction manual carefully.
- Non-professionals should not disassemble the machine, wrong reassembly may cause electric shock or fire. If you need maintenance or repair, please contact the after-sales service center.
- For your safety, please disconnect all power and cables of this equipment before maintenance or cleaning.
- Note: Non-professionals are not allowed to install this device and battery.
- In order to ensure the best working condition of this device, please select the appropriate cable size correctly.
- Please try to avoid using metal tools near the battery. If you must use it, please be careful. Dropping the tool may cause sparks or short circuits on the battery or other electrical components, or even cause an explosion.
- When disconnecting the AC or DC terminals, please strictly follow the installation steps. For details, please refer to the "Installation" section of this manual.
- Grounding Instructions - This equipment should be connected to a permanently grounded wiring system. Be sure to follow local requirements and regulations when installing this equipment.
- Do not short-circuit the AC output and DC input, and do not connect the mains when short-circuited.

1 Overall introduction

This manual mainly introduces product information, functional operation, equipment installation and maintenance guidelines. This brochure does not cover all information related to photovoltaics.

1.1 Overall description

This product photovoltaic-storage integrated machine: photovoltaic energy storage integrated energy conversion device, a device used in photovoltaic and energy storage combined power generation systems to realize DC/AC power conversion , adopts power electronic control technology, and can coordinate Control the output of photovoltaic and energy storage batteries, stabilize the power fluctuations of photovoltaic batteries, and output AC power that meets the standard requirements through energy storage and conversion technology to supply power to the load.

1.2 Main features and performance of functions

The company's Hybrid inverter adopts advanced digital control technology, which optimizes the control performance and improves the reliability of the system. Modern design, easy to install and maintain. The equipment has dynamic adjustable working mode, off-grid mode switching, photovoltaic energy power tracking, constant power charging/discharging function, constant voltage current limiting function, reactive power adjustment function, photovoltaic arc detection, photovoltaic input lightning protection, reverse Island protection, strong overload capacity, 110% overload can run for 2 hours, 120% can run for 2 minutes. support completely unbalanced load. system scalability is strong, the number of DC side circuits can be expanded according to actual needs. and energy storage batteries Fine management and other functions and features. Adopting the way that photovoltaic and energy storage are collected through the DC/DC common DC bus, the control is flexible and the stability is high. It can not only realize the MPPT control of photovoltaic, but also adapt to different types of energy storage, give full play to the adjustment range of energy storage, and optimize The charge and

discharge control of energy storage improves the utilization rate of energy. Its comprehensive LCD display provides user-configurable and easy-to-access button operations such as battery charging, AC/solar charging, and acceptable input voltage based on different applications.

1.3 Product Appearance Introduction

The appearance of this product and its various descriptions are shown in Figure 1.1 and Table 1.1 below.

Table 1.1 Description of product definitions

Number	Definition	Description
1	Indicator light	
2	LCDdisplay screen	
3	Function buttons	
4	Battery forced start button	
5	Grid switch	
6	PV input knob	
7	Meter-485 interface	
8	Battery input interface	
9	Functional interface	
10	ModBUS interface	
11	BMS interface	
12	PV input interface	With 2 MPPT
13	Load interface	
14	Gen interface	
15	WIFI interface	
16	CT interface	

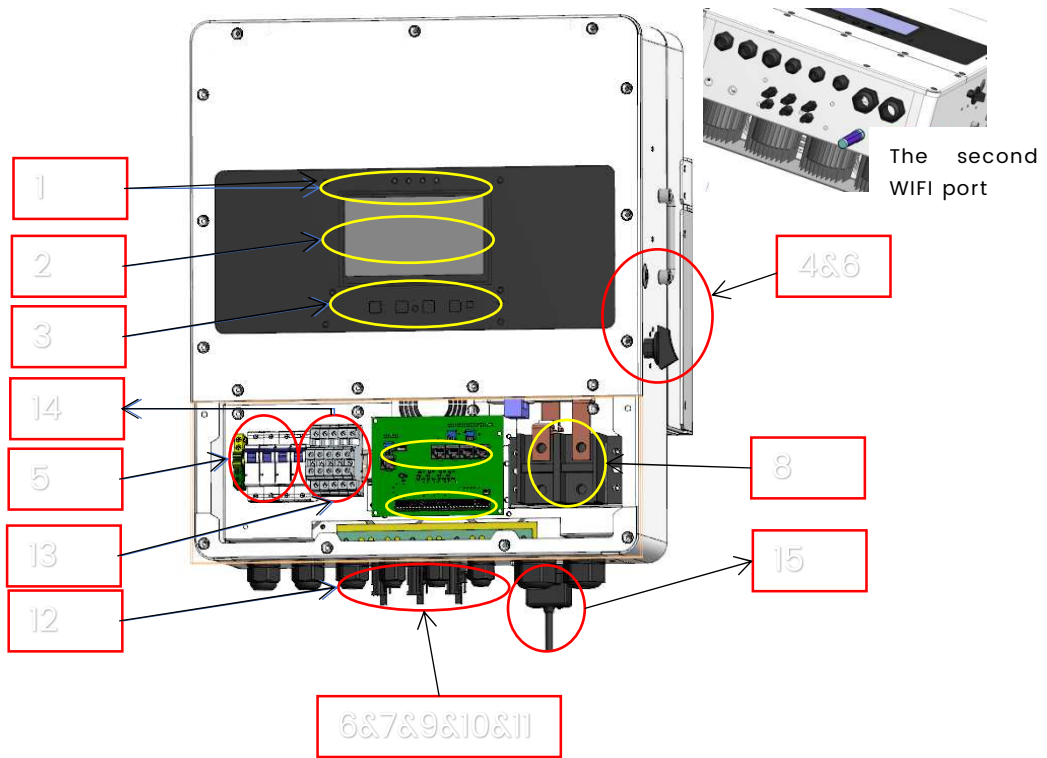
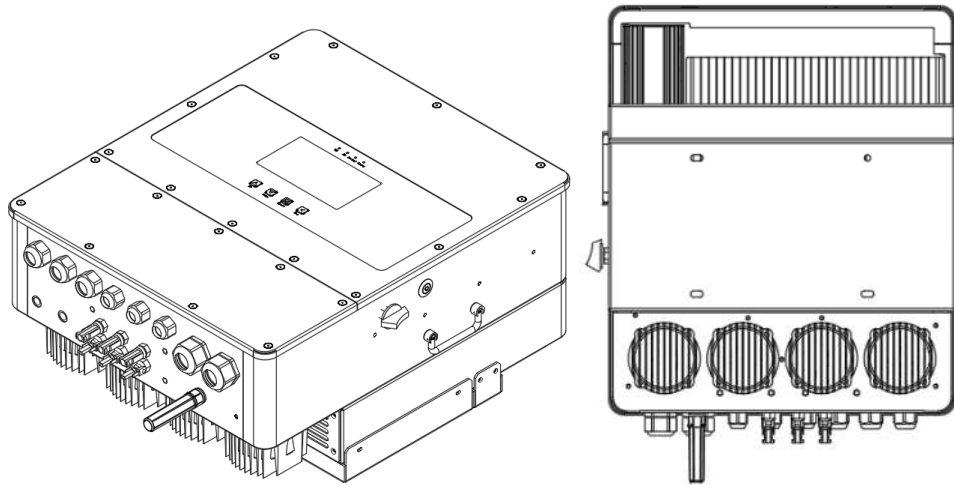

Figure 1.1 Overview of Hybrid Inverter Appearance

1.4 Size introduction

- Three-dimensional map



- Floor plan

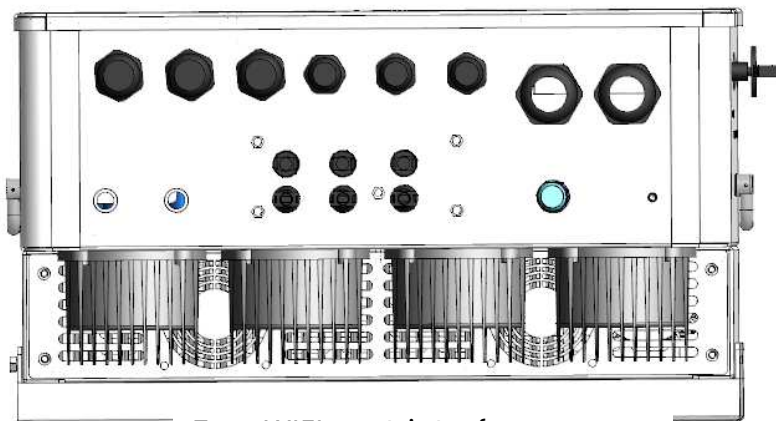
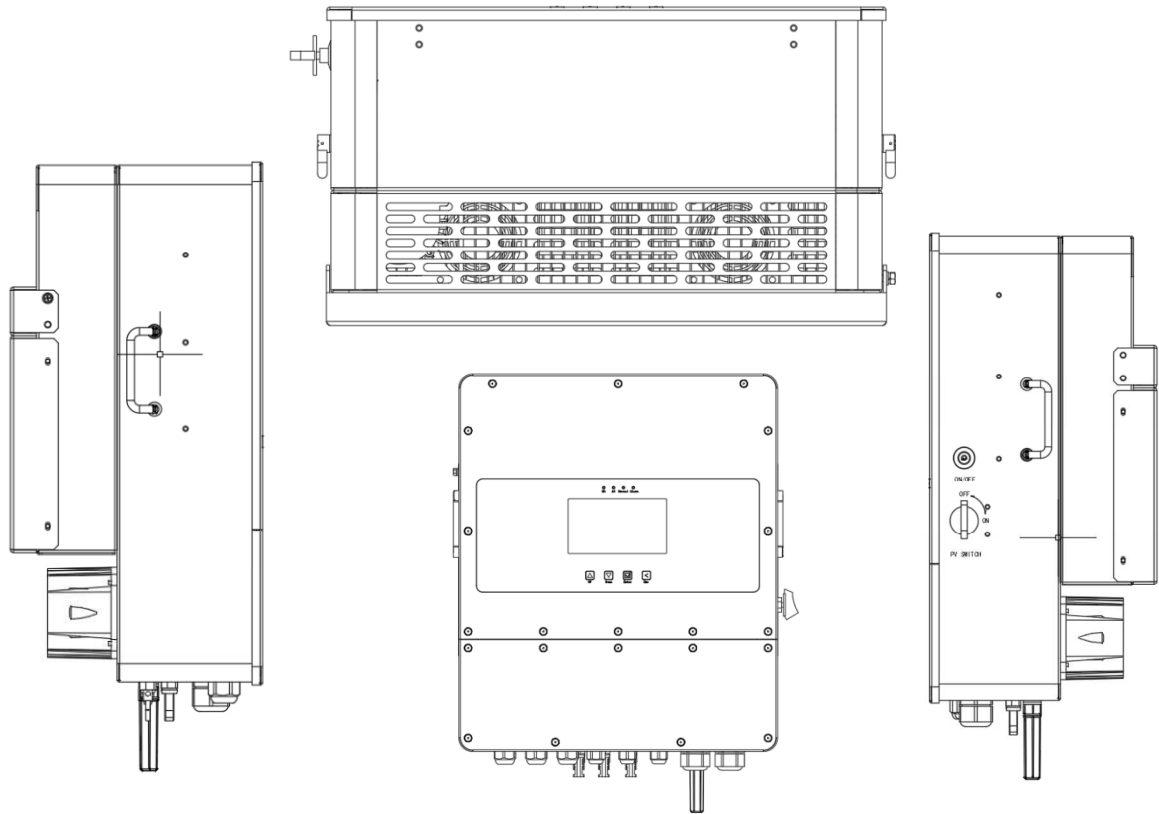

Two WIFI port interfaces

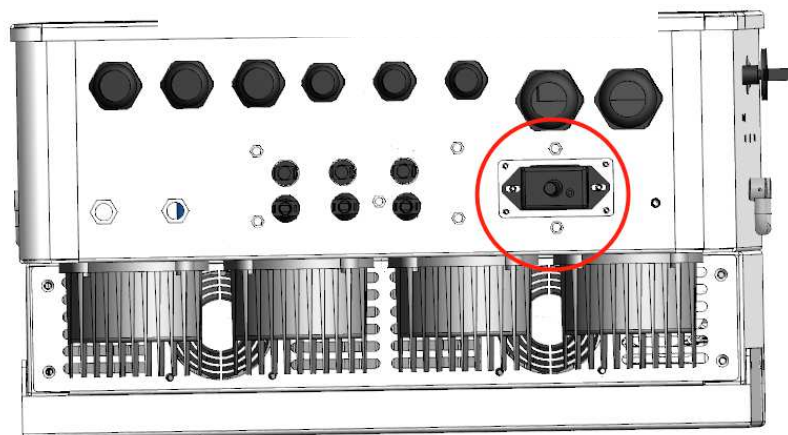

- Size W*H*D mm : 550x730x290.

- Weight kg : 45 .

1.5 System structure

As shown in Figure 1.2, it shows the basic application of the solar-storage integrated machine, and its complete operating system also includes: diesel generators, power grids, and photovoltaic modules.

Depending on your requirements, other possible system architectures are available from your system integrator. The device can power a variety of appliances in a home or office environment, including motor-type appliances such as refrigerators and air conditioners

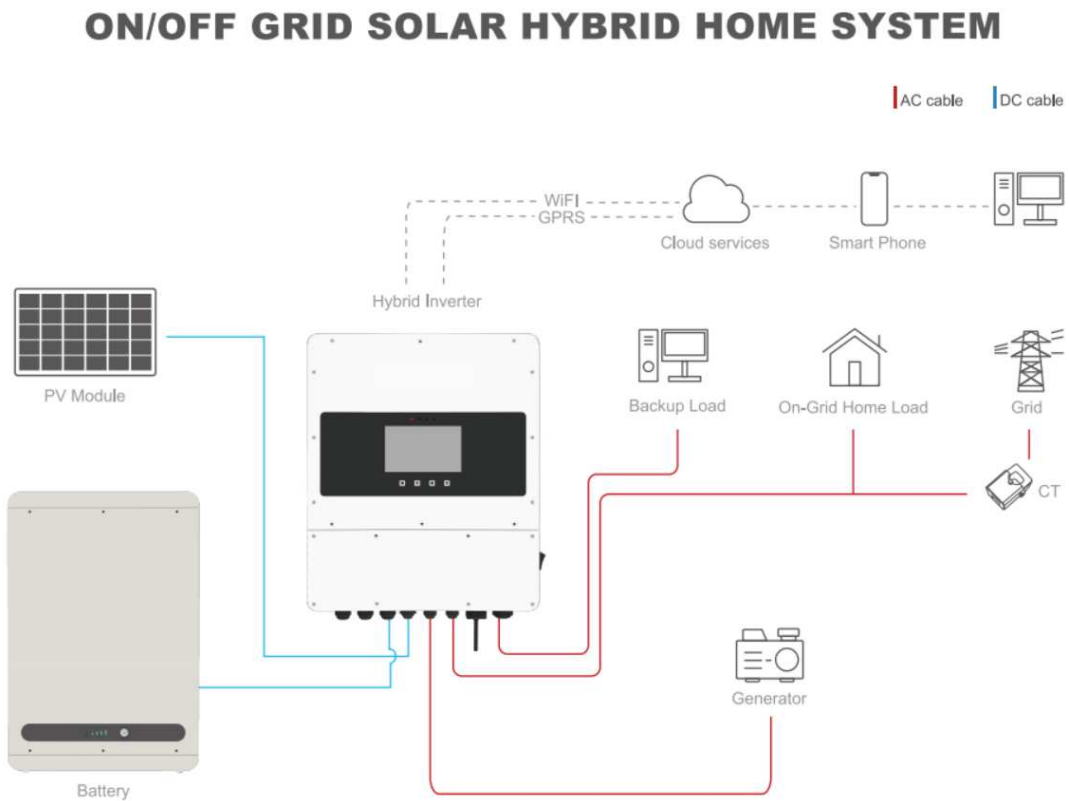

Figure 1.2 Complete operation system of hybrid inverter

1.6 Inverter parameter

The detailed technical specifications of this equipment are detailed in the annex.

2 Installation Instructions

2.1 Installation preparation

2.1.1 Installation Notes Reiterated

This device is designed for outdoor use IP65 , please ensure that the installation site meets the following conditions:

- out of direct sunlight.
- Not in areas where highly flammable materials are stored.
- Not in potentially explosive area.
- Do not expose directly to cold air.
- Keep away from TV antennas or antenna cables.

2.1.2 Installation environment, space requirements

To ensure the normal operation of the hybrid inverter, please install the equipment in a controlled environment. At the same time, in order to avoid overheating of the energy storage converter module, please keep the storage device ventilated smoothly. The ventilation holes and fans must not be blocked by sundries. The installation site must meet the following conditions:

- 1 Close to the power supply, easy to distribute power.
- 2 Clean and dust-free environment.
- 3 The altitude does not exceed 3000m, if it exceeds, the relevant national standards need to be installed for derating.
- 4 The ambient temperature is $-45\sim 60^{\circ}\text{C}$.
- 5 No corrosive, explosive and insulating gas and conductive dust, and keep away from heat sources.
- 6 No vibration and bumps, and the vertical inclination does not exceed 5%.
- 7 If the energy storage converter module operates in an air-conditioned environment around 20°C , it will improve reliability and prolong service life.

Consider the following points before choosing an installation location:

- For installation, please choose a vertical wall with strong load-bearing capacity, suitable for installation.
- On concrete or other non-flammable surfaces, install as shown in figure 1.3 below.
- Install this inverter at the line of sight level so that the LCD display can be read at any time.
- The ambient temperature should be between -45°C and 60°C to ensure the best operation.

- Please install the equipment in a position with sufficient distance reserved, as shown in figure 2.1 to ensure sufficient heat dissipation and enough space to remove the stitches. For proper air circulation to dissipate heat, leave a gap of approximately 1000mm. Lateral 500mm, upper and lower 500mm, and anterior outflow of 1000mm.

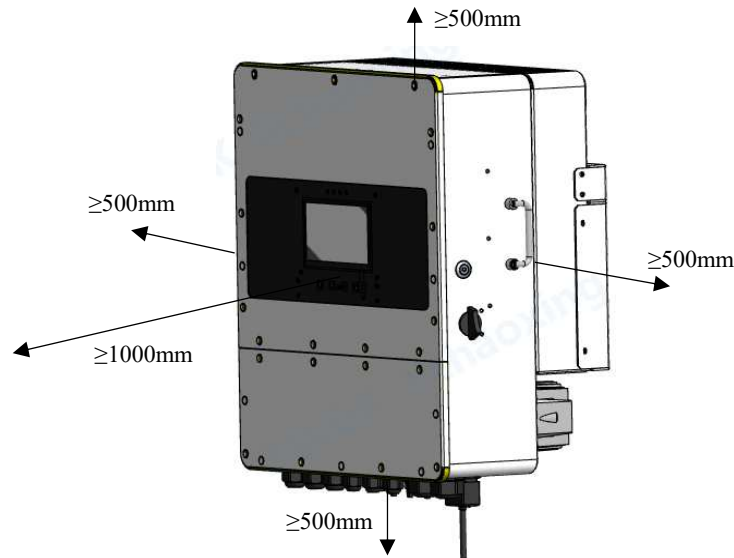

Figure 2.1 recommended reserved distance around the equipment

2.1.3 Installation tool preparation

Phillips screwdriver specification: PH2, moderate length, diameter 5.5mm, 10mm, 13mm wrench or sleeve for M3, M6, M8 outer hexagon screws

2.1.4 Inspection of out-of-box accessories

Please check the equipment before installation. Please make sure that there is no damage to the packing. The package you receive should include the items in Table 2.1, as shown in figure 2.2 below.

Table 2.1 Product list details

Serial number	Item name/specification	Quantity	Remarks
1	Inverter this equipment	1	
2	User manual	1	Place in the box
3	Shipment inspection report	1	Optional
4	V07.00001.05 mounting bracket	1	
5	Hardware/screws/stainless steel built-in expansion screws, hexagonal internal expansion bolts, implosion M8*80	4	For securing the chassis
6	Allen stainless steel combination screws M6X16	4	For fixing small enclosures
7	Allen stainless steel combination screws M4X12	4	For fixing large enclosures
8	Wi-Fi Stick	1	Shipped with the shipment
9	Current sensor/AKH-0.66 K- ϕ 24 100A/50mA Class 1	3	
10	Communication cable/Cat5e super 5 category 5 finished network cable 2 meters long	1	For communication with the host computer
11	CAN parallel wire/twisted pair shielded wire 2m	1	For parallel operation
12	PV input connector/MC4/line end female end/H4CFD2TMS/nut with pin	3	
13	PV input connector/MC4/line-end male/H4CMD2TMS/nut with pin	3	
14	Smart Meter/DTSD1352-C	1	Optional
15	Hardware/stainless steel screws/M3*12 hexagonal stainless steel combination screws	2	Optional Fixed WIFI stick
16	Battery Temperature Sensor/NTC Temperature Sensor B3950 10K thermistor, stainless steel waterproof probe 3 meters long	1	Optional
17	Certificate	1	
18	Warranty card	1	
19	PVESS12K/PE transparent bag/transparent ziplock bag 160*320	3	Assembly accessories, accessories, etc
20	Excipients / environmental protection / desiccant / 5g / pack	1	Packed in a box









 <p>Hybrid inverter×1</p>	<p>User manual</p> <p>User manual × 1</p>	<p>Shipment inspection report</p> <p>Optional</p> <p>Shipment inspection report × 1</p>	 <p>Wall mounting bracket×1</p>
 <p>stainless steel anti-collision bolt M8x80 ×4</p>	 <p>Allen stainless steel combination screws M6X16 X4 For fixing small enclosures</p>	 <p>Allen stainless steel combination screws M4X12 X4 For fixing large enclosures</p>	 <p>WIFI-Stick ×1</p>
 <p>Sensor Clamp ×3</p>	 <p>Communication cable×2m</p>	 <p>CAN parallel line×2m</p>	 <p>PV input connector/MC4 line end male//H4CFD2TMS/With pin nut - /X3</p>
 <p>PV input connector/MC4 line end male//H4CMD2TMS/With pin nut + /X3</p>	 <p>(Optional) Smart Meter × 1</p>	 <p>(Optional) Stainless steel screws/M3*12 hexagonal stainless steel combination screws</p>	 <p>(Optional) NTC Battery Temperature Sensor × 1</p>
<p>CERTIFICATE OF APPROVAL</p> <p>CERTIFICATE OF</p>	<p>WARRANTY CARD</p> <p>WARRANTY CARD × 1</p>	 <p>Self-sealing bags ×3</p>	 <p>Self-sealing bags ×3</p>

Figure 2.2 Product list details

2.2 Introduction of equipment terminal

The definition of the keys near the LCD is shown in figure 2.3. The definition of the connection socket and through hole at the bottom of the equipment is shown in figure 2.4. the definition of the button and knob on the side of the equipment is shown in figure 2.5. the internal

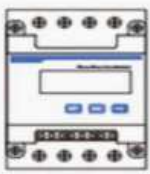
and external interface board of the equipment is shown in figure 2.6. the corresponding terminal definition is shown in Table 2.2.

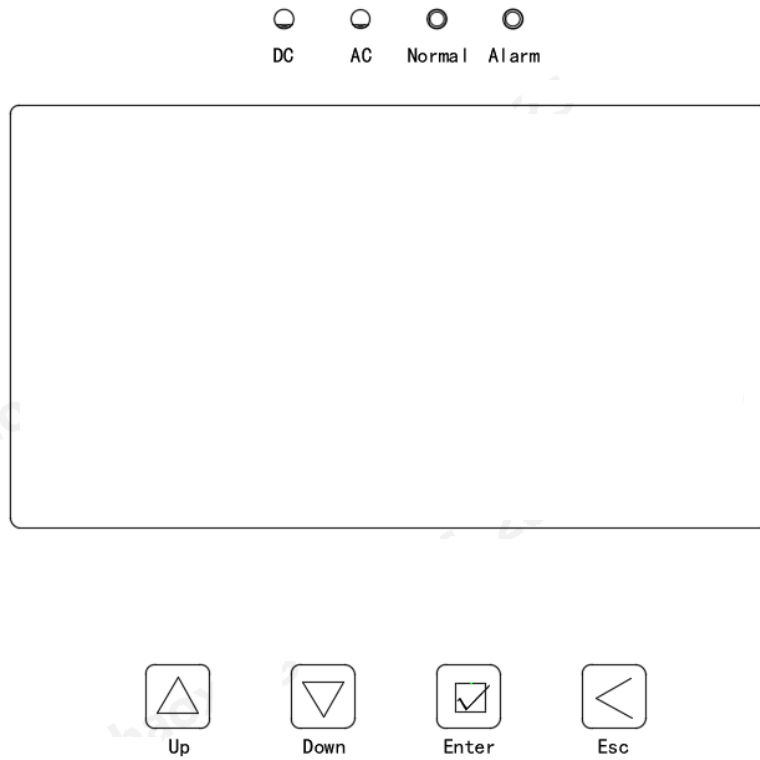
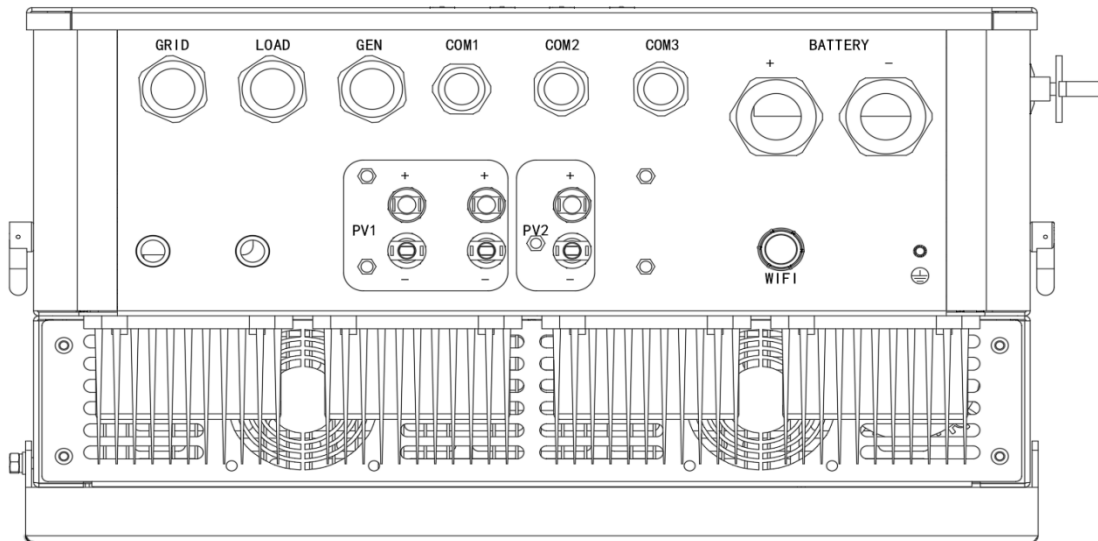

Figure 2.3 key definition near LCD



The second WIFI port:

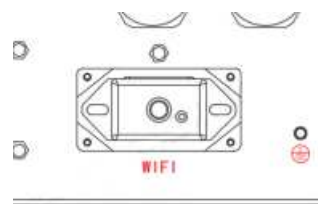

Figure 2.4 definition of socket terminal at the bottom of the device

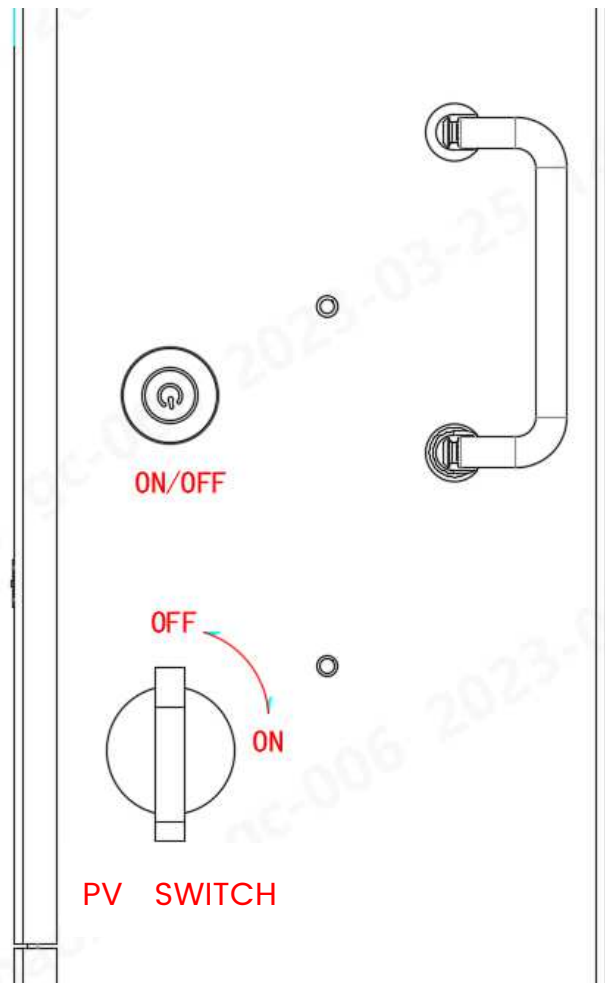

Figure 2.5 definition of side buttons and knobs on the device

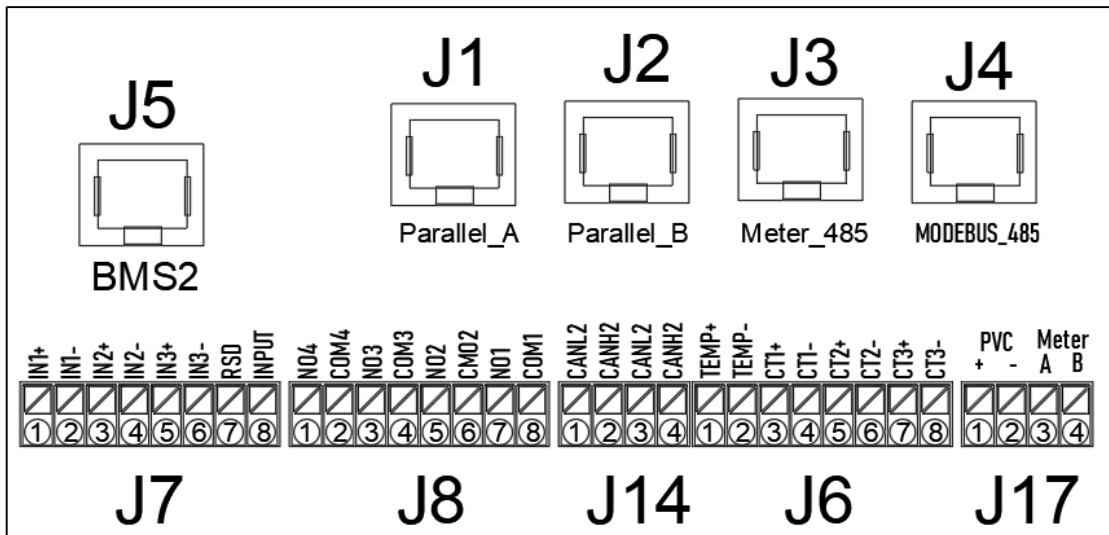

Fig. 2.6 schematic diagram of internal and external interface board of equipment

Table 2.2 definition of device internal external interface board

Pin tags	1	2	3	4	5	6	7	8	
Snap-on terminal tag	J7	INI+	INI-	IN2+	IN2-	IN3+	IN3-	RSD+	RSD-
	Definition	Reserve for spare						12V+output	12V+GND
	J8	NO4	COM4	N03	COM3	NO2	COM2	NO1	COM1
	Definition	Reserve for spare		Grid relay control		Gen adjustment control		Gen start control	
	J6	BAT-TEMP	ISOGND2	CT1+	CT1-	CT2+	CT2-	CT3+	CT3-
	Definition	Battery temperature sampling input		External A-phase CT1 sampling input		External B-phase CT2 sampling input		External C-phase CT3 sampling input	
	J14	SCANL2	SCANH2	SCANL2	SCANH2				
	Definition	Parallel CAN communication							
	J17	PV C	PV C	RS485A1	RS485B1				
Definition	PV control		Meter communication						
RJ45 network port number	J5	RS485B3	RS485A3	NC	CANH	CANL	NC	RS485A3	RS485B3
	Definition	BMS-485 communication			BMS-CAN communication			BMS-485 communication	
	J1	CANH1	CANL1	SNY-01	SNY-02	ISOGND1	ISOGND1	CAN-SMH	CAN-SML
	Definition	Parallel synchronous communication							
	J2	CANH1	CANL1	SNY-01	SNY-02	ISOGND1	ISOGND1	CAN-SMH	CAN-SML
	Definition	Parallel synchronous communication							
	J3	RS485B1	RS485A1	NC	NC	NC	NC	RS485A1	RS485B1
	Definition	Meter communication						Meter communication	
	J4	RS485B4	RS485A4	NC	RS485A4	RS485B4	NC	RS485A4	RS485B4
Definition	Background monitoring			Reserve background monitoring communications			Background monitoring		

2.3 Wall mount

Warm reminder, the equipment chassis is very heavy, please take it out carefully!

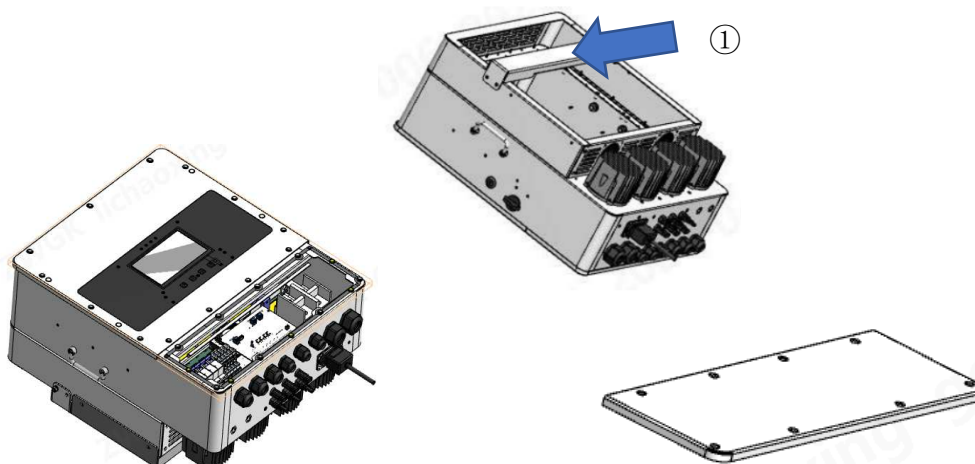

Figure 2.3 schematic diagram of device cover removal

- Take the equipment out of the package and secure the small bracket to the equipment with 4 M6 × 16 bolts, as marked ① in figure 2.3. tighten the bolts, remove the large bracket from the back of the equipment, and mark the installation wall according to the four bolt position dimensions 250X200mm in the middle of the large bracket panel.
- Select the recommended bit shown in figure 2.4 below to drill 4 holes in the wall with a depth of 52-60 mm.
- Use a suitable hammer to load the expansion bolt into the hole, fix the back cover plate to the bolt on the wall, and tighten the screw head of the expansion bolt.
- Carry the equipment and hold it, make sure that the small bracket of the equipment is aligned with the large bracket of the rear cover, and fix the equipment to the fixed rear cover plate on the wall.
- Ensure that the equipment is aligned with the four bolt holes on the side of the rear cover plate, tighten the four bolts on the side of the equipment and the rear cover plate, and complete the installation.

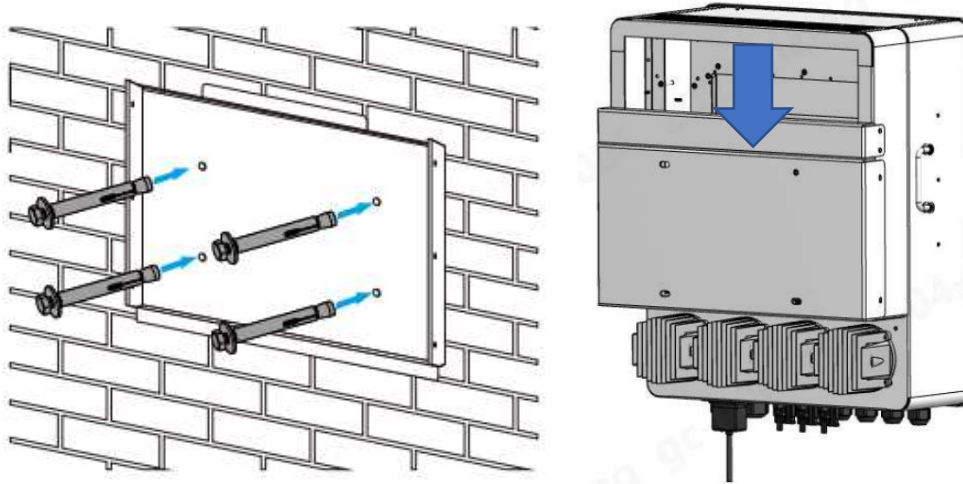

Fig. 2.4 schematic diagram of borehole location

2.4 Battery wiring work

For safe operation and compliance, a separate DC circuit breaker is required between the battery and the equipment. In some applications, switchgear may not be required, but circuit breakers still need to be disconnected. For the required fuse or circuit breaker specifications, please refer to the typical data selection in Table 2.2 below.

2.4.1 Battery Power Cable Wiring

For your safety and efficient operation of the equipment, please connect the battery with a suitable cable to reduce the risk of injury. You can also refer to the recommended cable shown in Table 2.2.

Table 2.2 Recommended cable example

Load power	Cable size	Cable size	mm ²	Torque value
10Kw	3/0AWG	70		24.5Nm
12Kw	4/0AWG	95		24.5Nm
14Kw	4/0AWG	95		24.5Nm



All wiring must be carried out by professionals!

Please select the appropriate battery cable and bolt, find the "Battery end hole" in the schematic diagram of "Figure 2.4 Definition Diagram of Socket Terminal at the Bottom of Equipment", and insert the cable into the correct through hole. Tips: Please pay attention to the positive +, negative - corresponding wiring . Use a suitable screwdriver to

unscrew the bolt, install the battery cable terminal, and then use the screwdriver to tighten the bolt to ensure that the bolt is tightened, the torque is 24.5Nm, clockwise, to ensure that the polarity of the battery and inverter is correctly connected.

Before making the final DC connection or closing/disconnecting the DC breaker, make sure that the positive + must be connected to the positive + and the negative - must be connected to the negative -. Reversed battery connections can damage the device.

2.4.2 Battery communication cable connection

As shown in Figure 2.5, the BMS of BAT_PACK is connected with the J5 network port in the figure, and the definition of the communication connection line is shown in Table 2.2.

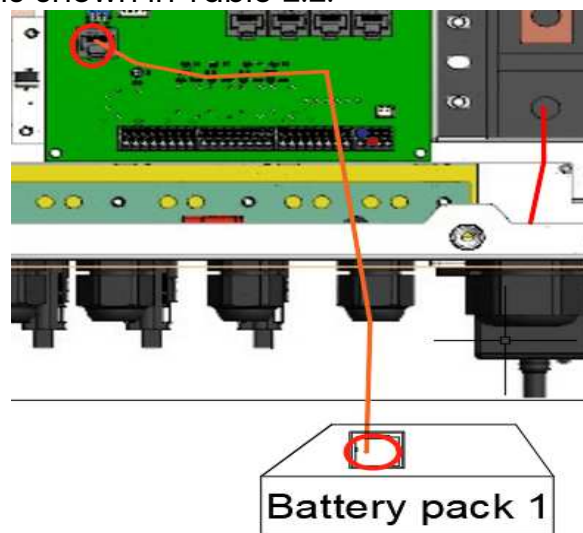

Figure 2.5 Schematic diagram of battery communication connection

2.5 Power grid, load, GEN wiring

Before connecting to the grid, please install a separate AC circuit breaker between the equipment and the power grid. In addition, it is recommended to install an AC circuit breaker between the spare load and the equipment. This ensures that the inverter can be safely disconnected during maintenance and is fully protected from overcurrent. It is recommended that the AC circuit breaker is 20A/20A/30A for 10KW/12KW/14KW. The recommended AC cable size is 12AWG, with each 4~6mm² cable. There are three terminals marked "Grid", "Load" and "GEN". Please do not mistakenly connect input and output connectors.

All wiring must be performed by qualified personnel. Using a suitable cable for AC input connection is very important for the safe and efficient operation of the system. To reduce the risk of injury, use the correct recommended cable, as shown in figure 2.6 below.



Please make sure that the AC side power supply is open before connecting.

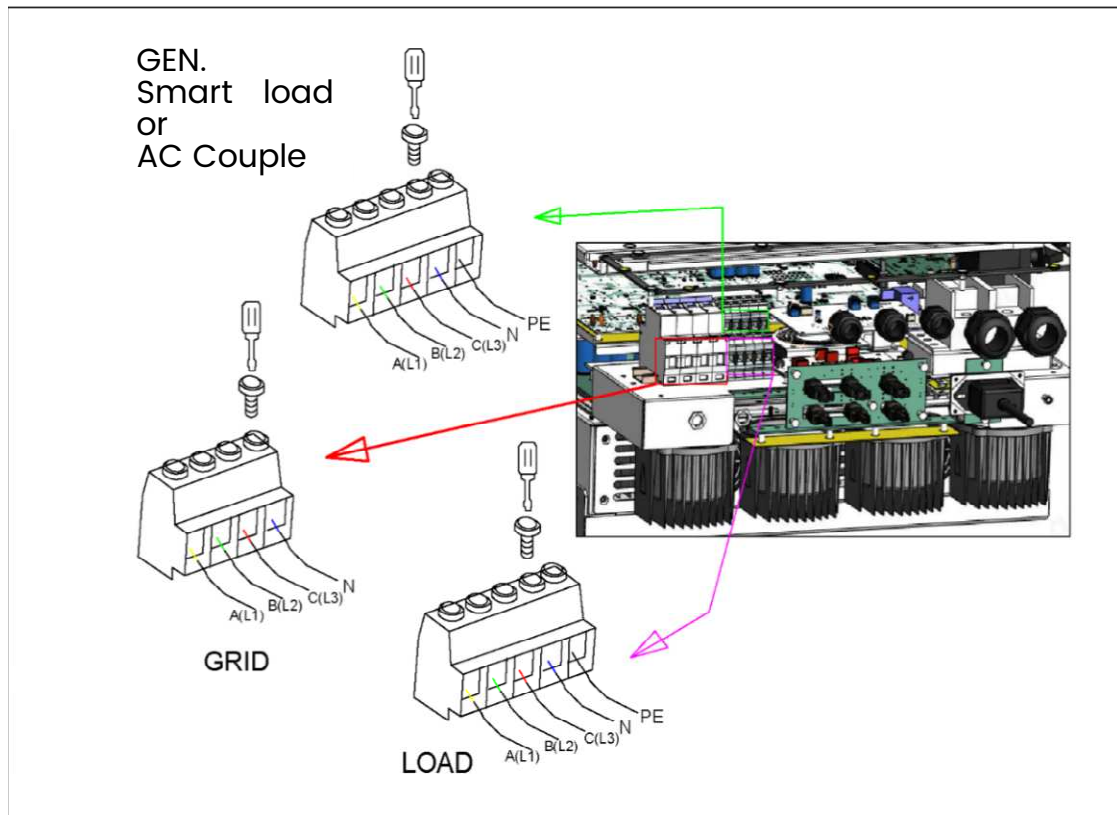

Figure 2.6 connection of power grid, load and engine

Follow these steps to connect the Grid grid, Load load, and Gen generator ports:

- Be sure to turn off the AC circuit breaker or isolation switch before connecting the power grid, load, and generator.
- Remove the 10mm long insulating sleeve, unscrew the bolts, insert the wire according to the polarity marked on the terminal, and tighten the wiring screw. Make sure the connection is complete.
- Then insert the AC output wire according to the polarity marked on the terminal and tighten the terminal. Be sure to connect the corresponding N and PE wires to the relevant terminals to ensure that the wires are firmly connected.
- Electrical appliances such as air conditioners need at least 2-3 minutes to restart because they need enough time to balance the refrigerant gas in the loop. If a power shortage occurs and

recovers within a short period of time, it will cause damage to the equipment you are connected to. To prevent such damage, check whether the air conditioner manufacturer is equipped with a delay function before installation. Otherwise, this equipment will trigger an overload failure and cut off the output to protect your equipment, but sometimes it will still cause internal damage to the air conditioner.

2.6 Photovoltaic wiring

Before connecting the photovoltaic module, install a separate DC circuit breaker between the device and the photovoltaic assembly. Connecting photovoltaic modules with appropriate cables is very important for the safe and efficient operation of the system. To reduce the risk of injury, the recommended cable size is 12AWG, each 4mm² cable.

To avoid any failure, do not connect any photovoltaic components that may leak to the device. For example, a grounded photovoltaic module can cause current leakage to the device. Photovoltaic junction boxes with surge protection are required. Otherwise, when the photovoltaic module is struck by lightning, the equipment will be damaged.



When using photovoltaic modules, make sure that there is no grounding.

- When using photovoltaic modules, make sure that there is no grounding:
 - 1.The open circuit voltage V_{oc} of the photovoltaic module does not exceed the maximum open circuit voltage of the photovoltaic array photovoltaic integrated storage machine.
 - 2.The open circuit voltage V_{oc} of the photovoltaic module should be higher than the minimum starting voltage of the integrated photovoltaic storage machine.

Table 2.3 description of photovoltaic module selection

Argument	10~14KW
PV Input Voltage	650V 160V~800V
MPPT Range	200V~700V
No. of MPPT Tracker	2
No. of String Per MPPT Tracker	2+1

● Photovoltaic module wiring

- 1 Turn off the main AC circuit breaker of the power grid.
- 2 Close the DC circuit breaker.
- 3 Assemble the photovoltaic input connector as shown in Figure 2.7 at the bottom of the device.



Safety tips: Do not ground the positive or negative electrode of the photovoltaic panel device, otherwise it will seriously damage the inverter.



Safety tip: Before connecting, please ensure that the polarity of the output voltage of the photovoltaic panel device is consistent with the "DC+" and "DC-" symbols.



Safety tip: Select a qualified DC cable: 4~6mm² 12~10AWG single cable .

Safety tip: Before connecting the inverter, ensure that the open circuit voltage of the photovoltaic panel device is within 1000V



Figure 2.7 Photovoltaic input connector: DC+ connector left DC-Connector right

● The steps for assembling DC connectors are as follows:

1. Peel off the DC line about 7mm and remove the connector cover nut see figure 2.8 .

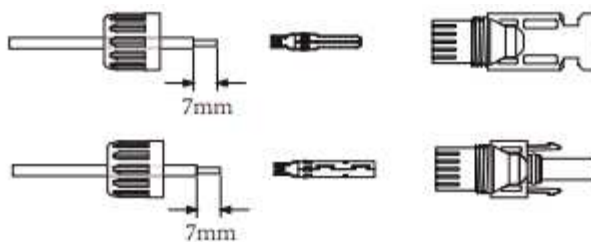

Figure 2.8 Connector cover nut

2. Crimp the metal terminal with crimping pliers, as shown in figure 2.9.

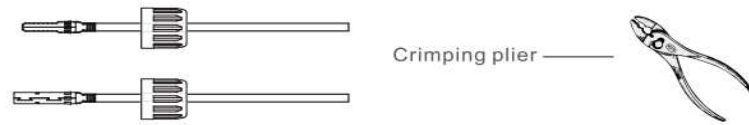

Figure 2.9 Crimping clamp crimping metal terminal

3. Insert the stylus into the top of the connector and screw the cover nut to the top of the connector. figure 2.10 .

4. Finally, insert the photovoltaic DC connector into the positive and negative input of the Hybrid inverter, as shown in figure 2.11.

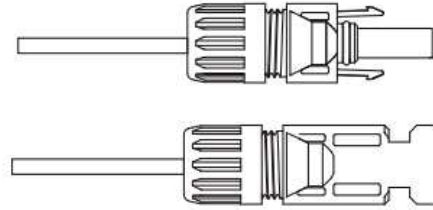

Figure 2.10 Stylus inserted into the top of the connector

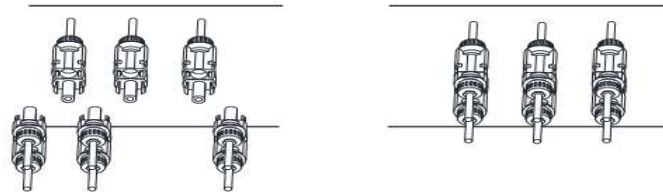

Figure 2.11 The DC connector is inserted into the positive and negative input of the hybrid inverter equipment.



Warning: sunlight on the panel will generate voltage, high voltage series may be life-threatening. Therefore, before connecting the photovoltaic DC input line, the solar panels need to be blocked by opaque materials, and the DC switch should be turned off, otherwise the high voltage of the equipment may be life-threatening.

2.7 CT wiring

In the power grid cable, as shown in figure 2.12, three current transformers are passed through three phases, the direction arrow of the transformer faces the equipment side, and the transformer sampling line reaches the internal interface board J6 sampling terminal through the equipment COM3 through hole. At the same time, the J6 terminal is connected to the battery temperature sampling signal line.

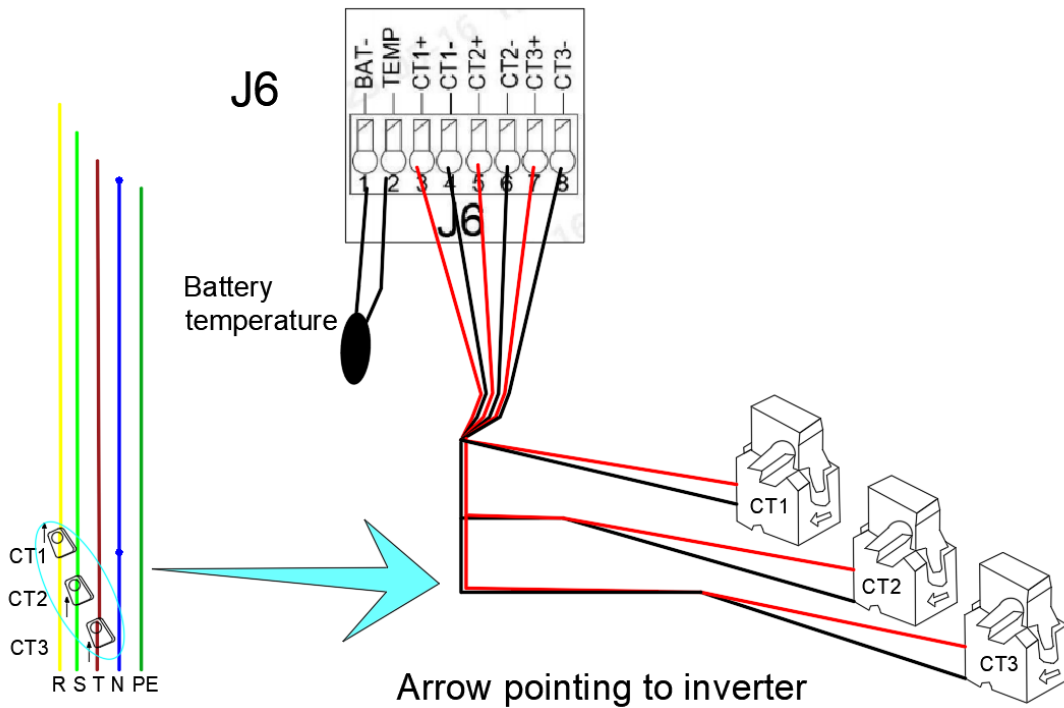



Figure 2.12 schematic diagram of external CT wiring and battery temperature sampling wiring

2.8 Ground connection

The grounding wire should be connected to the grounding floor on the side of the power grid to prevent electric shock. In the "grounding identification" bolt hole in the definition diagram of the socket terminal at the bottom of the equipment in figure 2.13 .

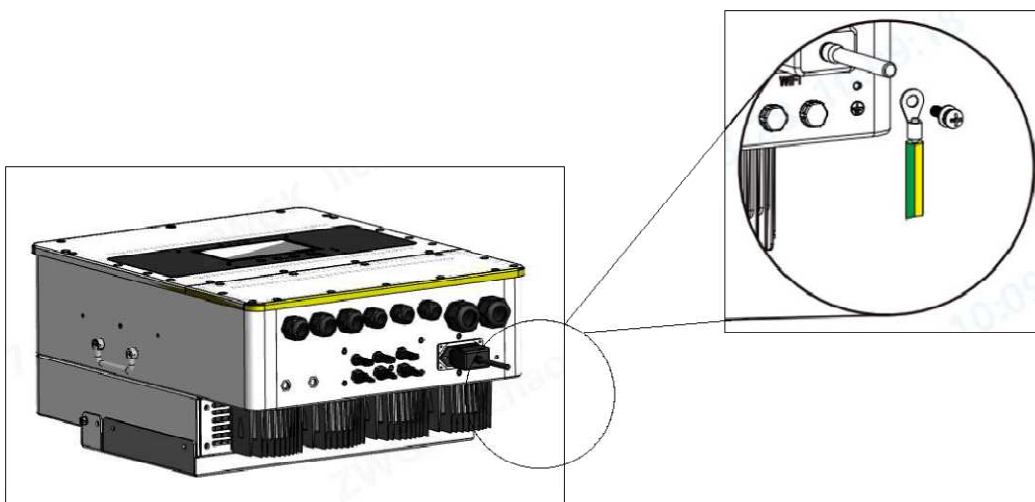

Fig. 2.13 Schematic diagram of equipment grounding

2.9 WIFI connection

For the configuration of Wi-Fi, please refer to the schematic wiring of

Wi-Fi socket, and refer to the user manual of WIFI socket for details.

2.10 Stand-alone operation and logic description

When the stand-alone operation, Figure 2.6 The K6 dialing code on the internal and external interface board of the device needs to be opened, set ON, as shown in Figure 2.14. K8 and K7 remain closed.

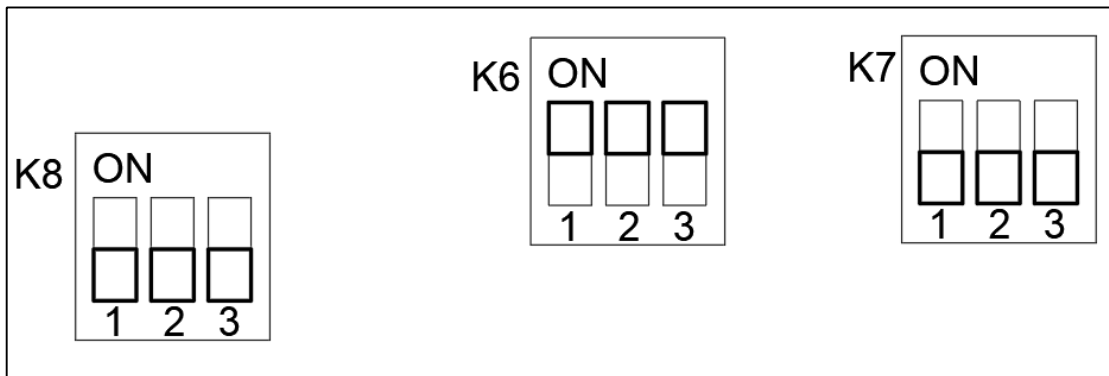

Figure 2.14 Schematic diagram of DIP terminal ON

2.10.1 Stand-alone operation system diagram

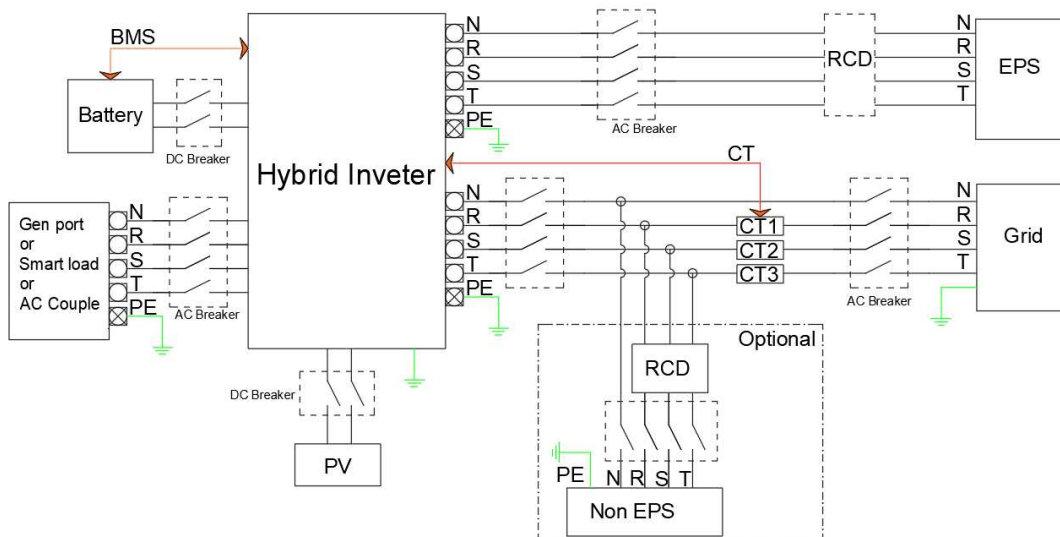

Figure 2.15 schematic diagram of stand-alone wiring

2.10.2 Enter working mode to set path

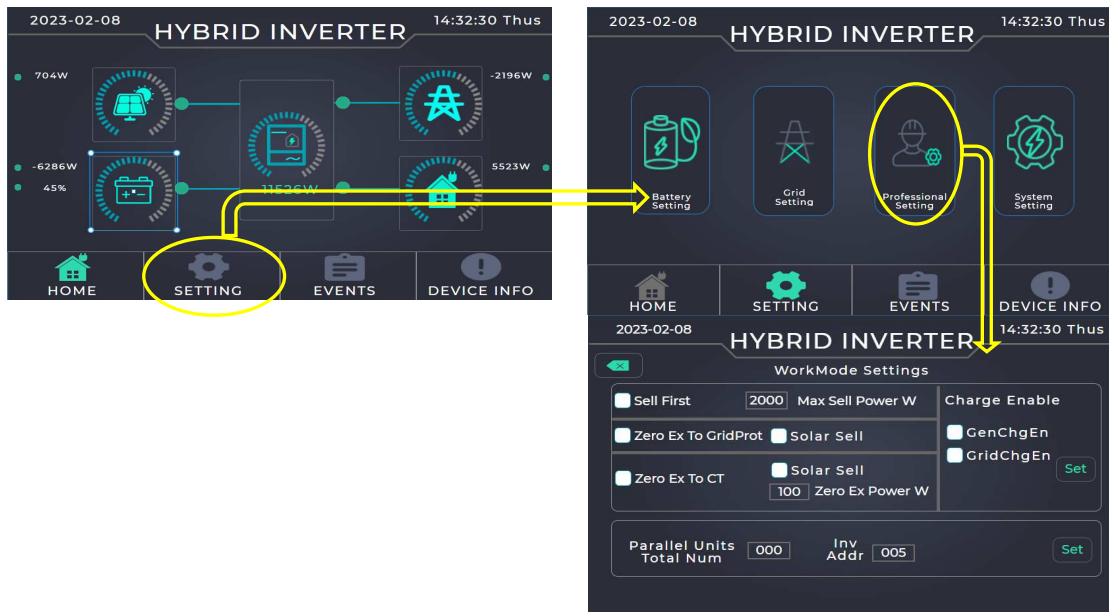

Figure 2.16 schematic diagram of entering the working mode

2.10.3 .Sell First

Priority mode of selling electricity. This mode allows hybrid inverters to sell excess photovoltaic power back to the grid, and it can also be sold to the grid when time permits and the battery energy is surplus the current capacity of the battery is greater than the minimum discharge SOC and the minimum discharge voltage setting value, but the selling power should be limited, and the total power set rule is the maximum load power and the power sold to the grid shall not exceed 12kW of its total inverter power. When photovoltaic power generation and battery energy can not meet the power consumption of the load, the power grid will be used as a supplementary power supply. At the same time, if time and conditions permit, you can also check "engine rechargeable" or "grid rechargeable" to use the power grid or engine to charge the battery.

2.10.4 Zero Ex To Grid Port

This mode hybrid inverter only supplies power to the connected "LOAD" local load. The hybrid inverter will neither provide power for the household load nor sell power to the grid. The built-in CT will keep the detected power flowing to the grid side to zero, while photovoltaic

power generation will only provide the local load and charge the battery. When the photovoltaic power generation is strong, the battery is full, and the load cannot be consumed. The inverter will operate with limited power excess photovoltaic power can also be sold to the grid if time permits: this function can be checked . When photovoltaic power generation and battery energy can not meet the load, it will be supplemented by the power grid. At the same time, if time and conditions permit, you can also check "engine rechargeable" or "grid rechargeable" to use the power grid or engine to charge the battery.

2.10.5 Zero Ex To CT

This mode hybrid inverter not only supplies power to the local load on the connected Load terminal, but also provides power to the home load. The external CT keeps the detected power flow to the grid side zero. Photovoltaic power generation can be provided to the local load and household load, and the battery can be charged. When the photovoltaic power generation is strong, the battery is full, and the load cannot be consumed. The inverter will operate with limited power excess photovoltaic power can also be sold to the grid if time permits: this function can be checked . When photovoltaic power generation and battery energy can not meet the load, it will be supplemented by the power grid. At the same time, if time and conditions permit, you can also check "engine rechargeable" or "grid rechargeable" to use the power grid or engine to charge the battery.

2.10.6 Time curve mode

Power grid peak regulation. Click on the home page to set "SETTING", click on the battery setting "BatterySetting" graph in the settings interface, you can enter the battery parameter setting interface, click the next page, check "TimeofUse" on the "BatterySetting3" page, and set the time curve related parameters, as shown in figure 2.17 below, you can choose the three time curve operation modes of "SOC-%", "Power-W" or "Bat-V" in the drop-down box.

The hybrid inverter in this mode operates according to the set time period and the corresponding allowable conditions, and the battery

discharge power will be limited to the set value. If the load power exceeds the allowable value, photovoltaic will be used as a supplement. If it still can not meet the load demand, then increase the grid power to meet the load demand. At the same time, if time and conditions permit, you can also check "engine rechargeable" or "grid rechargeable" in the working mode interface to charge the battery using the power grid or engine.

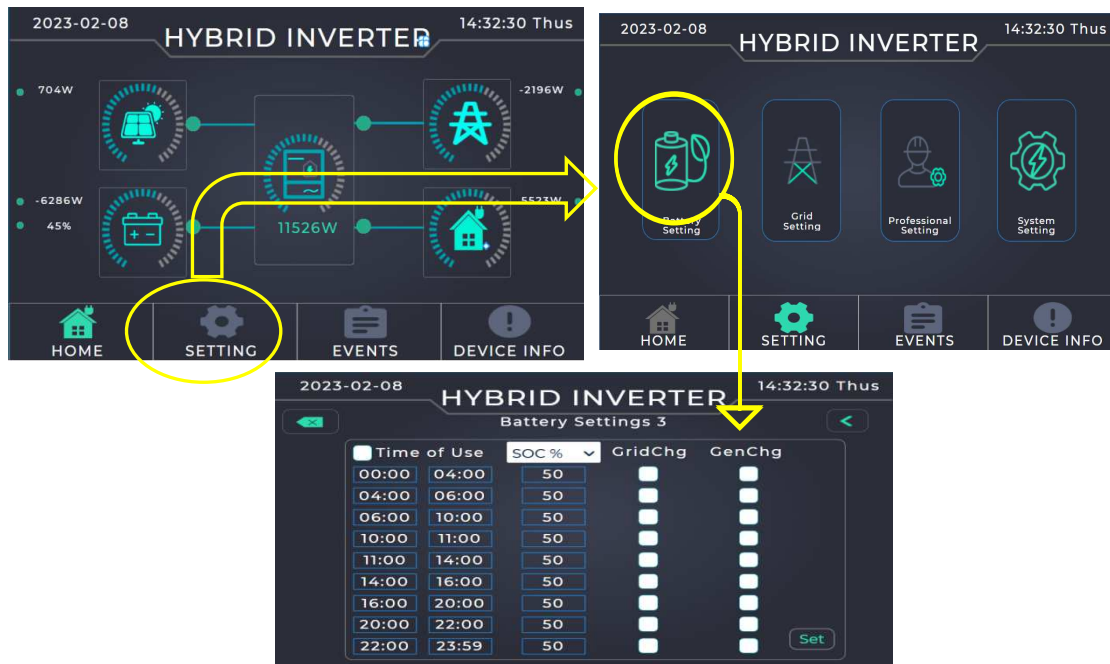

Figure 2.17 Schematic diagram of setting time curve

2.11 Parallel operation and logical explanation

When running in parallel, the internal and external interface board of the first device and the last device is placed as shown in Figure 2.6 K6 dialing code needs to be opened,"ON", K8 and K7 are currently closed. This is shown in Figure 2.14. For example, in Figure 2.19 of the grid-connected parallel wiring diagram, the three devices need to be placed, and the K6 dialing code of 1# and 3# needs to be opened, and the dialing code of 2# does not need to be opened.

2.11.1 Set entry path description

Click "SETTING" on the home page, and click "ProfessionalSetting" in the setting interface to enter the working mode setting interface and select the address setting of the device, as shown in figure 2.18.

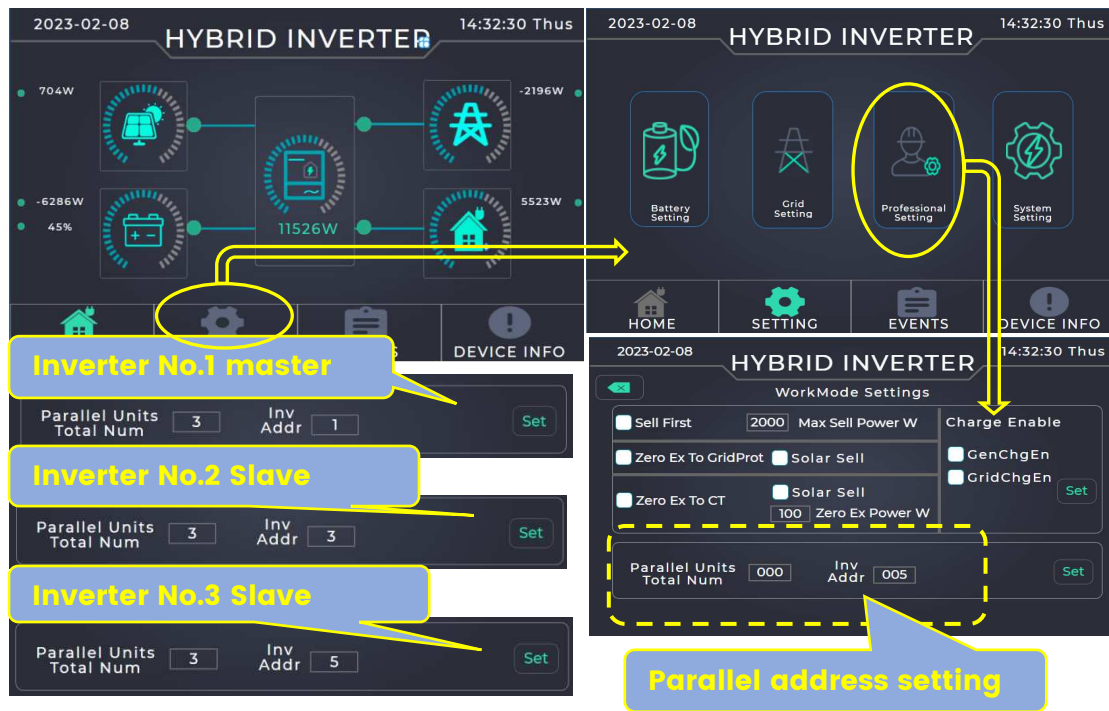

Figure 2.18 Enter the parameter setting diagram of the parallel machine and the address setting of the three machines

2.11.2 Parallel operation logic

When multiple parallel machines are connected, first connect the communication network lines ports Parallel_A and Parallel_B and CAN communication lines port J14CAN2HandCAN2L of the parallel equipment to form a ring connection system, then set the address parameters of each module respectively after power-on, as shown in figure 1.1. set the number of parallel machines "ParallelUnitsTotalNum", inverter address "InvAddr" can only be odd, man-machine HMIParaAddr recommended starting from 1 can not be repeated. The hybrid inverter module of InvAddr=1 will be defined as the host by the system, and the hybrid inverter module whose InvAddr is odd will be defined as the slave.

In this mode, all hybrid inverters will run synchronously according to the scheduling of the host, so when powering up, the boot keys of all slaves should be pressed first, and finally the boot keys of the mainframe should be pressed, so that the host can automatically identify the slave state in the merging system, which is conducive to logic and power regulation when power is turned on and connected to the grid. If there is an individual slave failure or communication

interruption in the normal operation, the host will automatically identify and withdraw the slave from the whole parallel system and re-regulate the power. When the fault slave returns to normal, the host will automatically identify and merge the slave into the system and re-regulate the power. All the working modes of the parallel system are the same as those of the stand-alone machine. It should be noted that the parallel machine only needs a set of external CT, which is connected to the municipal power trunk line, and the sampling signal is connected to the CT input port of the host computer.

2.11.3 Parallel system wiring diagram

As shown in Figure 2.19 on grid parallel wiring diagram, Figure 2.20 off grid parallel machine wiring diagram. When the GRID or GEN or AC Couple is connected, it is connected to the grid at this time, and the parallel wire needs to be connected according to the diagram. When the GRID ,GEN and AC Couple are not connected, there is no need to connect the parallel wire for off-grid parallel operation at this time. When multiple devices share a set of batteries and are paralleled, select BatShareEn on the System Setting interface.

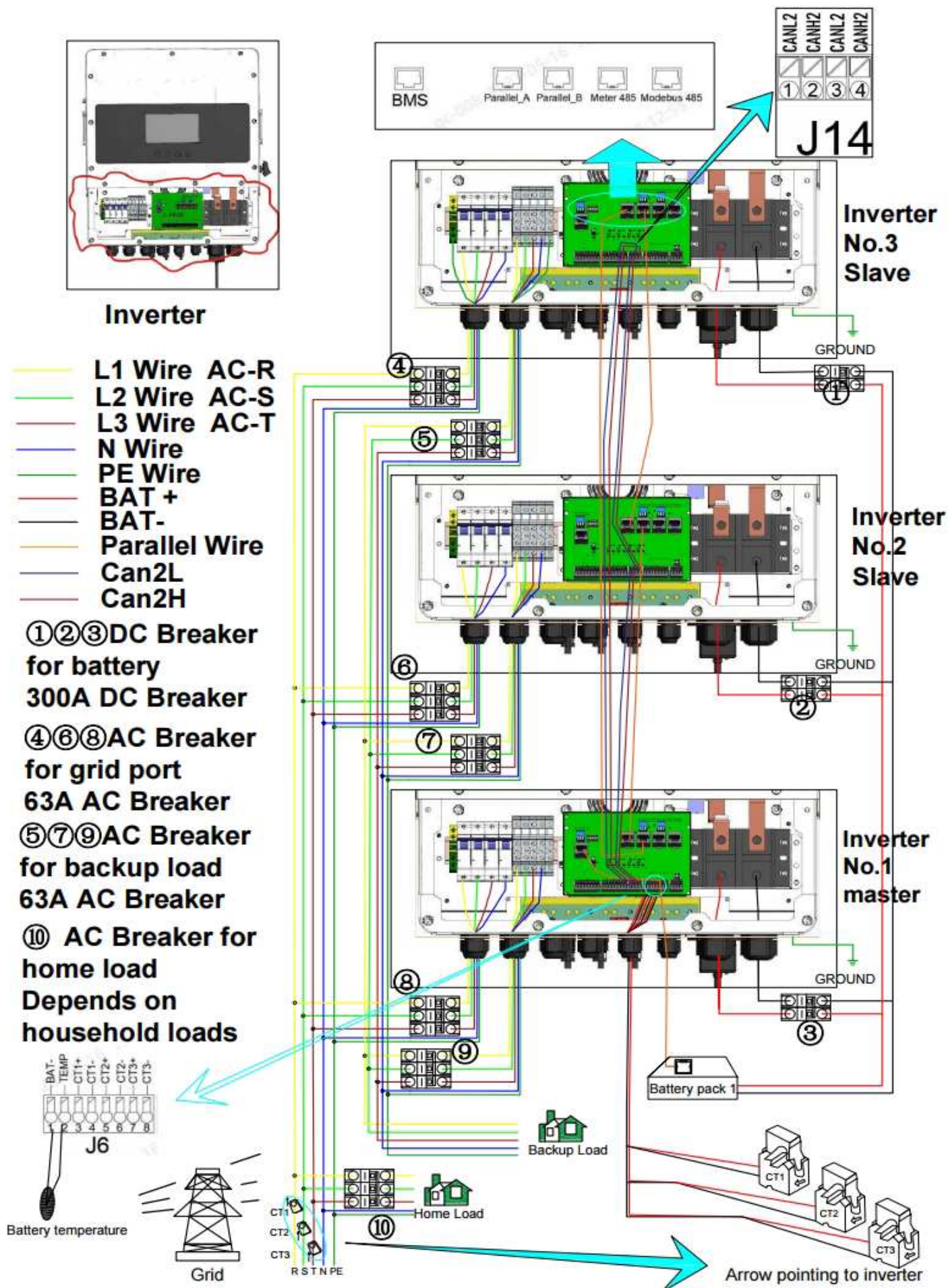

Figure 2.19 On-grid parallel wiring diagram

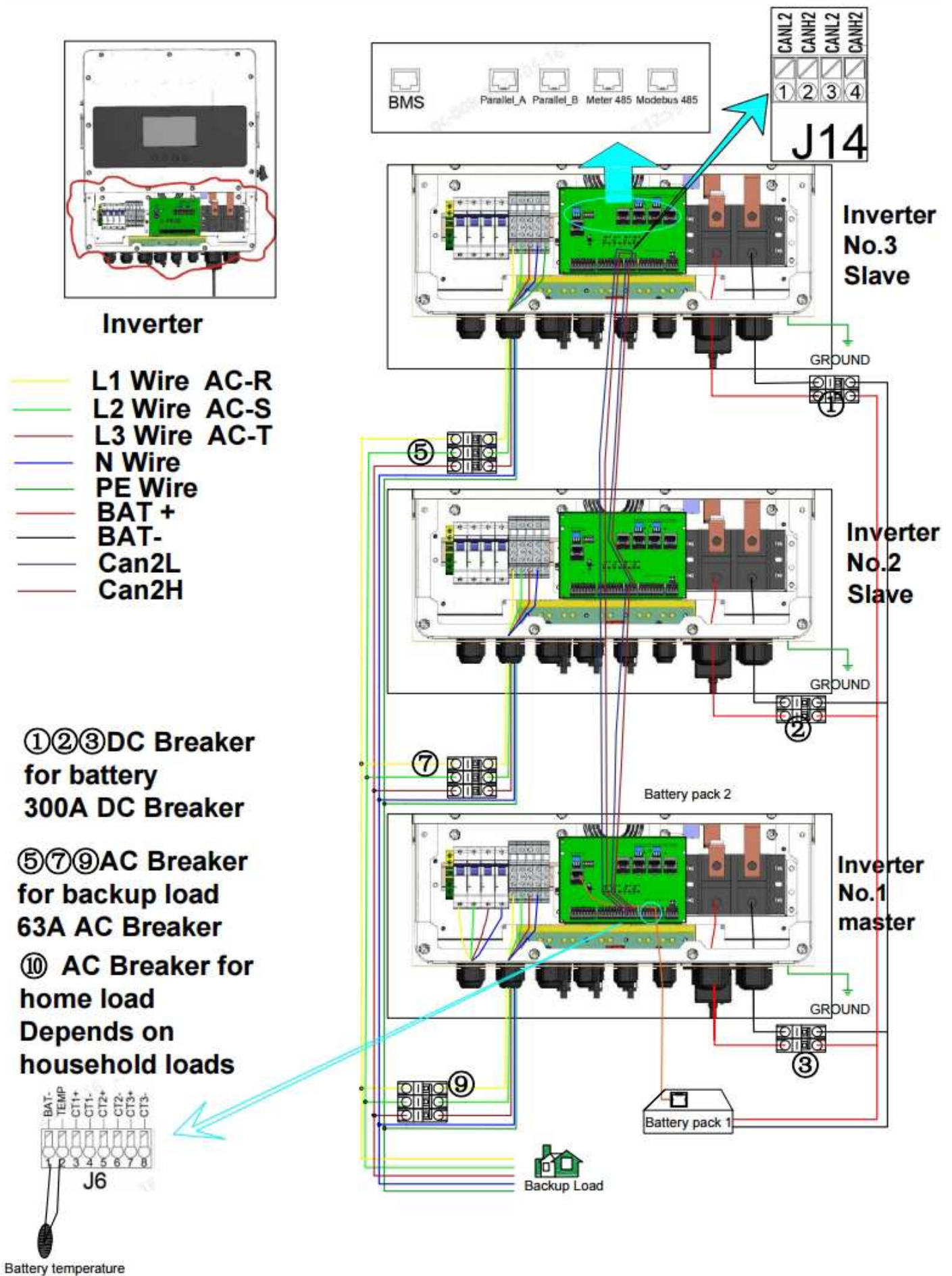

Figure 2.20 Off-grid parallel wiring diagram

3 Display and setup

3.1 Run data display instructions

Note: All LCD passwords are 750912

The topology of the LCD screen is shown in Figure 3.1, and the main interface is shown in Figure 3.2A. The main screen displays information including solar energy, grid, load and battery. It also shows the direction of energy, shown in Figure 3.2B. flow by dots, so the system information is displayed vividly on the main screen, and the photovoltaic power and load power are always positive. Negative grid power means that it is connected to the grid, and positive means it is obtained from the grid. The negative pole of the battery power supply is charged, and the positive pole is discharged. The bottom icons are "Home", "Setting", "Events", "DeviceInfo"

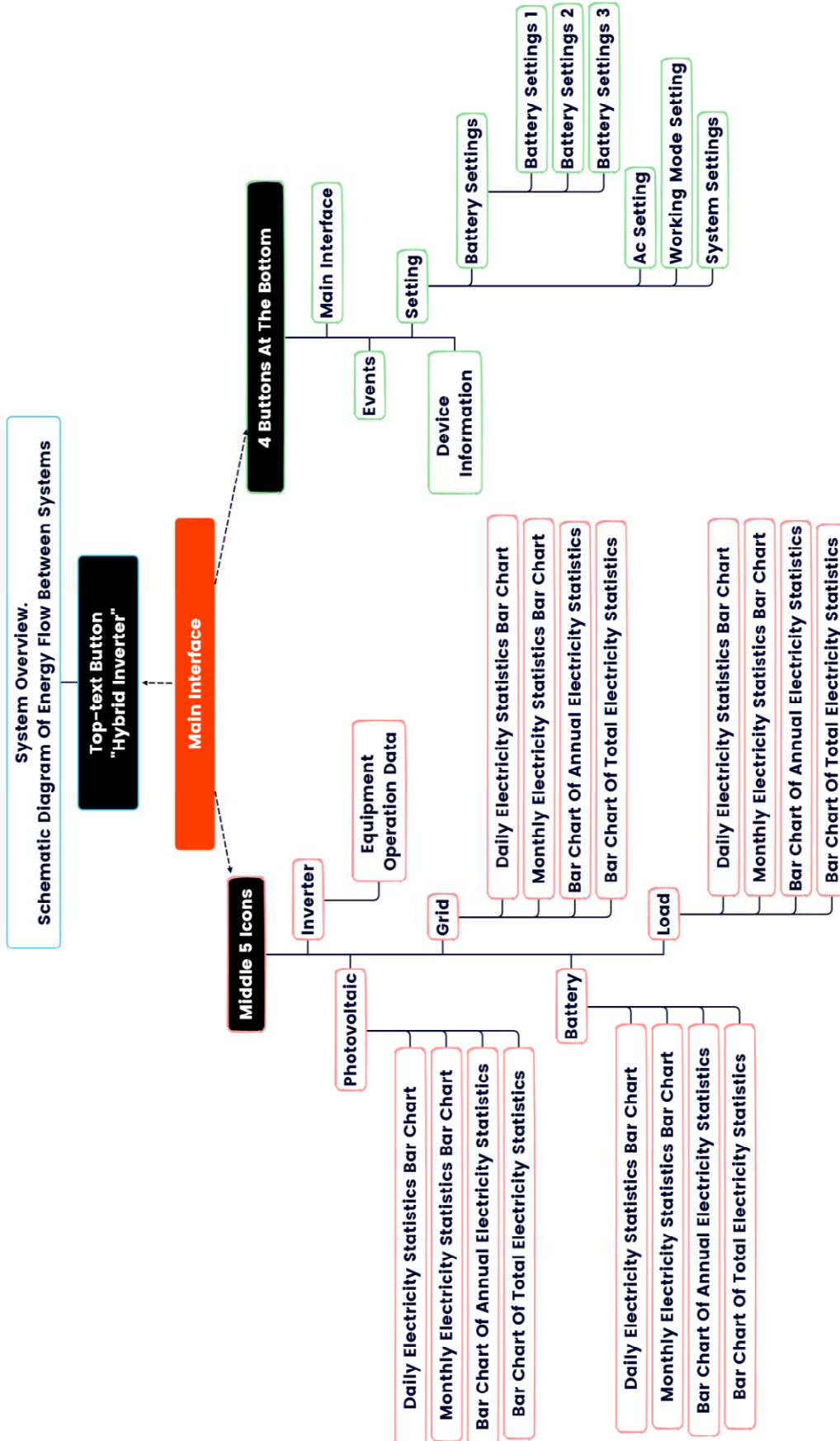

Figure3.1 LCD Topology structure diagram

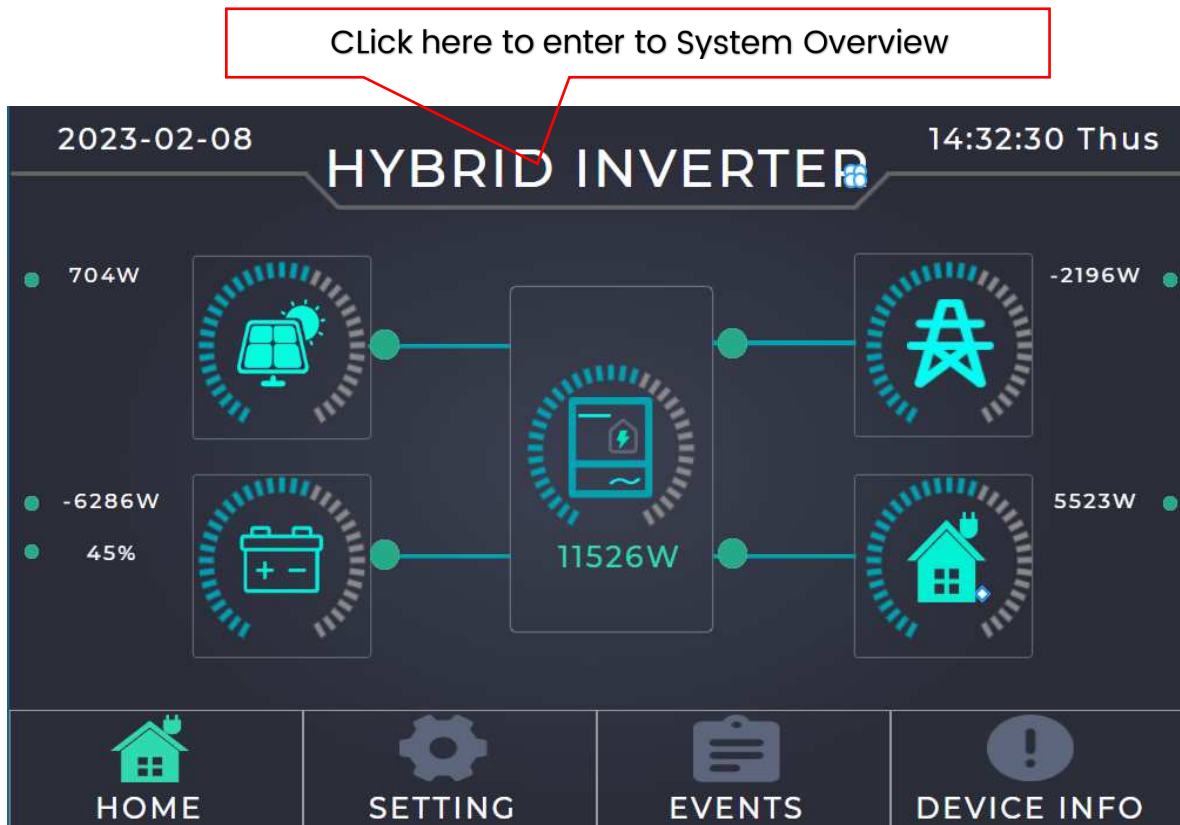

Figure3.2A LCD Main interface

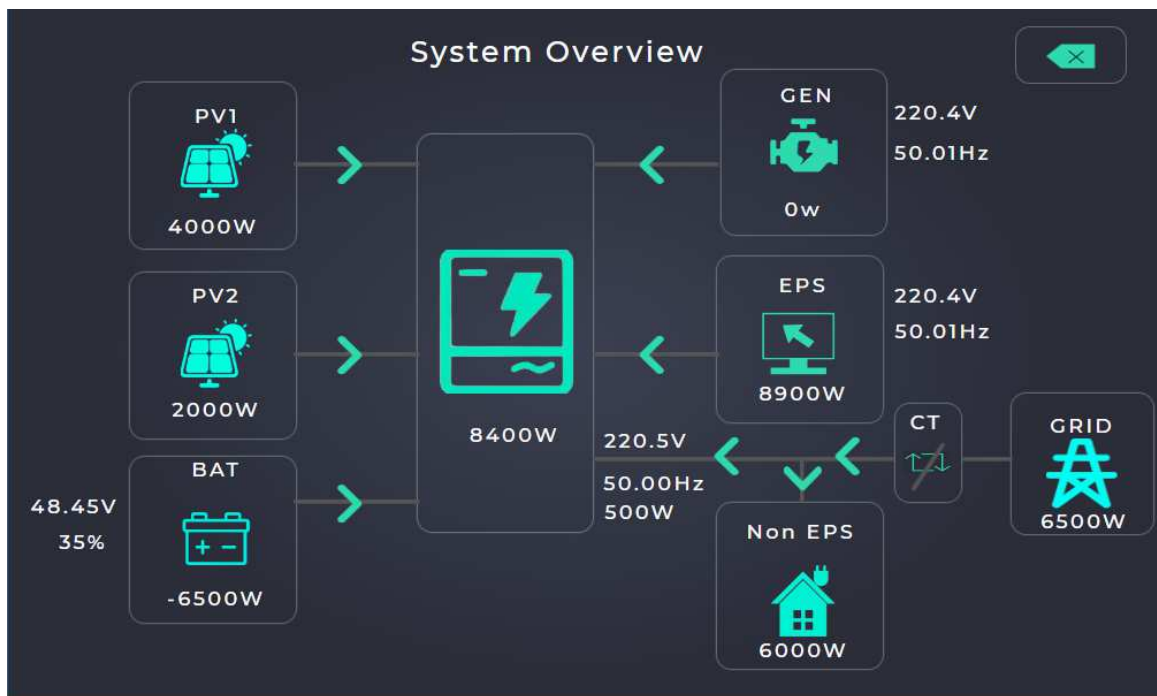

Figure3.2B System Overview

3.1.1 Photovoltaic data

Click the photovoltaic panel icon on the panel of the main interface to view its annual, monthly, daily, and current electricity statistics, as shown in Figure 3.3~3.6 below. The meaning of “Stage” on the left side of the interface is shown in Table 3.1. Click DEL on this interface to delete all photovoltaic power statistics. Click the arrow on the right side of the interface to view the data of other dates.

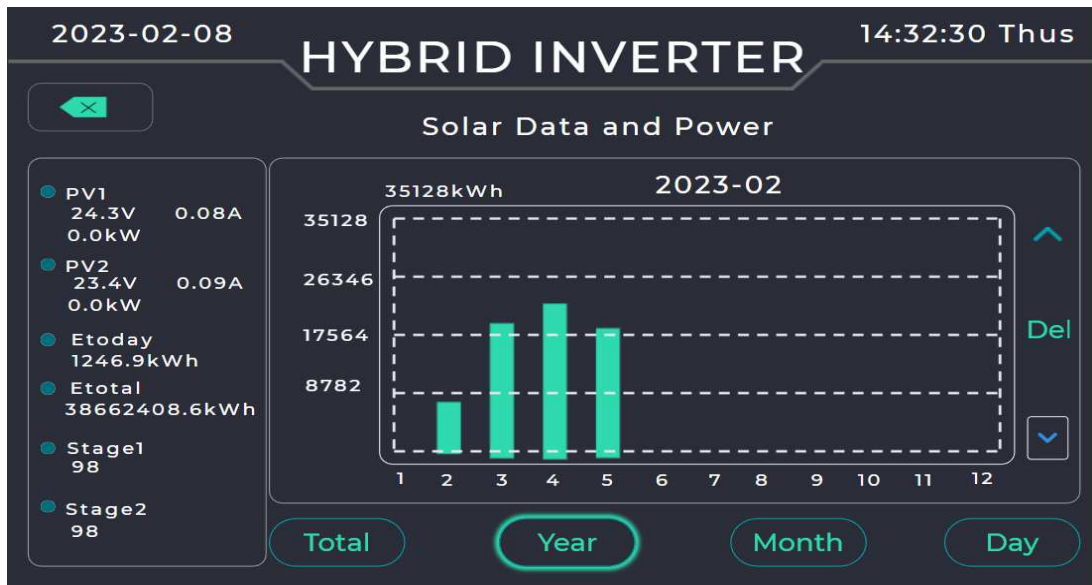

Figure 3.3 Annual Statistical Data of Photovoltaic Power Generation

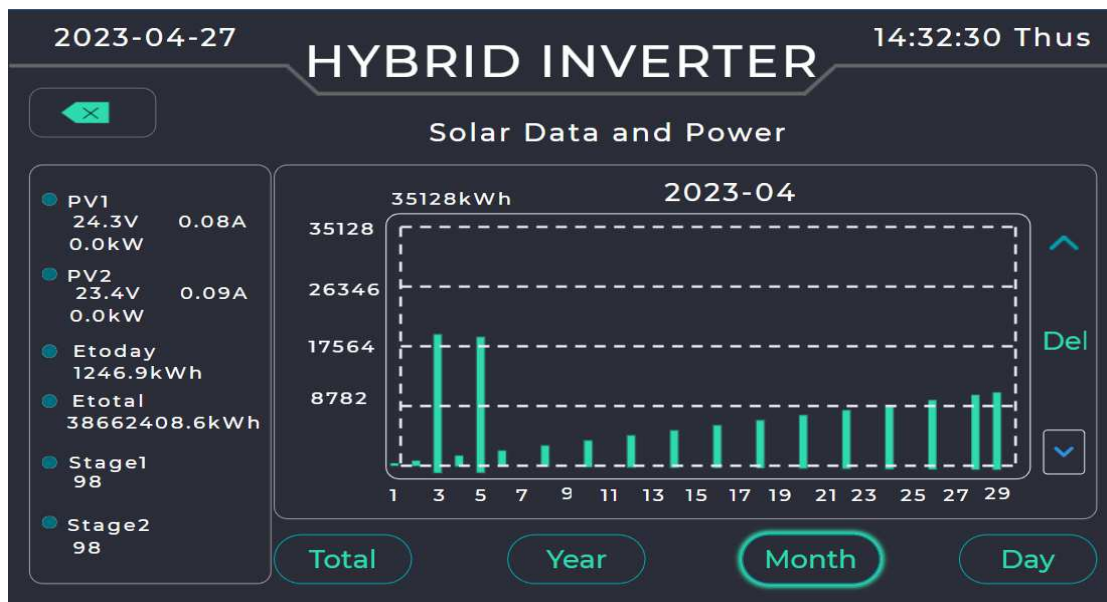

Figure 3.4 Monthly Statistical Data of Photovoltaic Power Generation

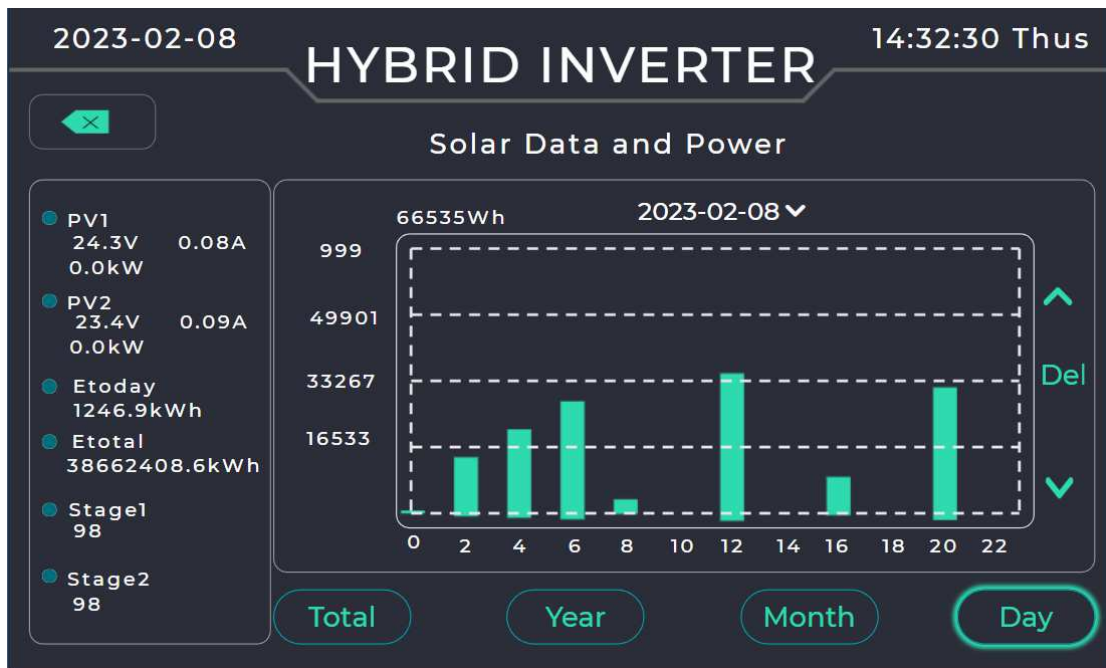

Figure 3.5 Daily statistical data of photovoltaic power generation

Table3.1 PV stage illustrate

Stage	Number	Illustrate
PV Stage	98	Standby
	30	Normal working

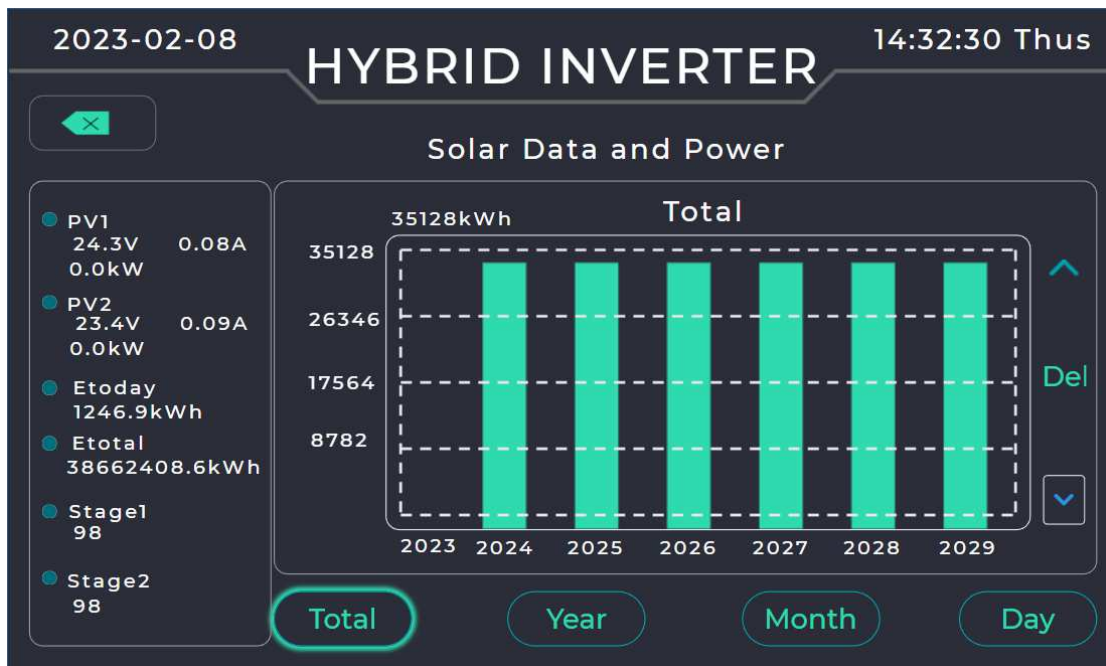

Figure 3.6 All measurement data of photovoltaic power generation

3.1.2 Battery data

Click the battery icon on the main interface to view its annual, monthly,

daily, and current battery statistics, as shown in Figure 3.7 below. The meaning of Stage on the left side of the interface is shown in Table 3.2. Click DEL on this interface to delete all battery statistics. Click the arrow on the right side of the interface to view the data of other dates.

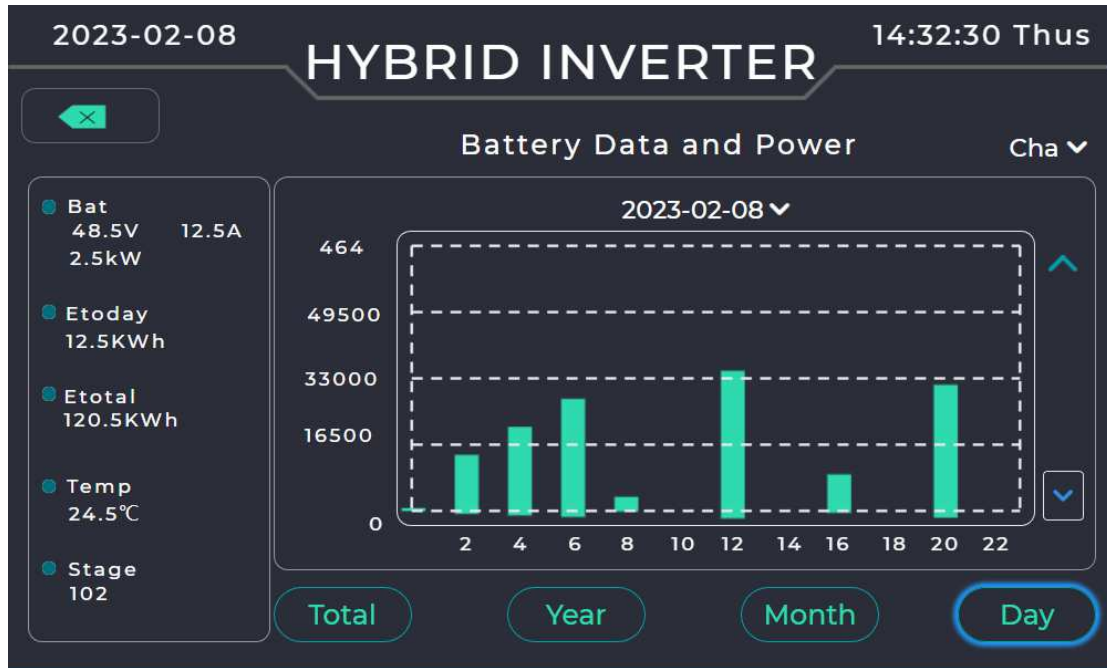

Figure 3.7 Statistical diagram of battery power data, etc.

Table 3.2 DC stage description

Stage	Number	Illustrate
DC Stage	102~129	Protect shutdown
	101	
	201	Shutdown
	231	
	89	Standby
	10	Normal off-grid operation

3.1.3 Inverter data

Click the middle inverter icon on the main interface to view the running data, as shown in Figure 3.8 below. The meaning of Stage on the right side of the interface is shown in Table 3.3

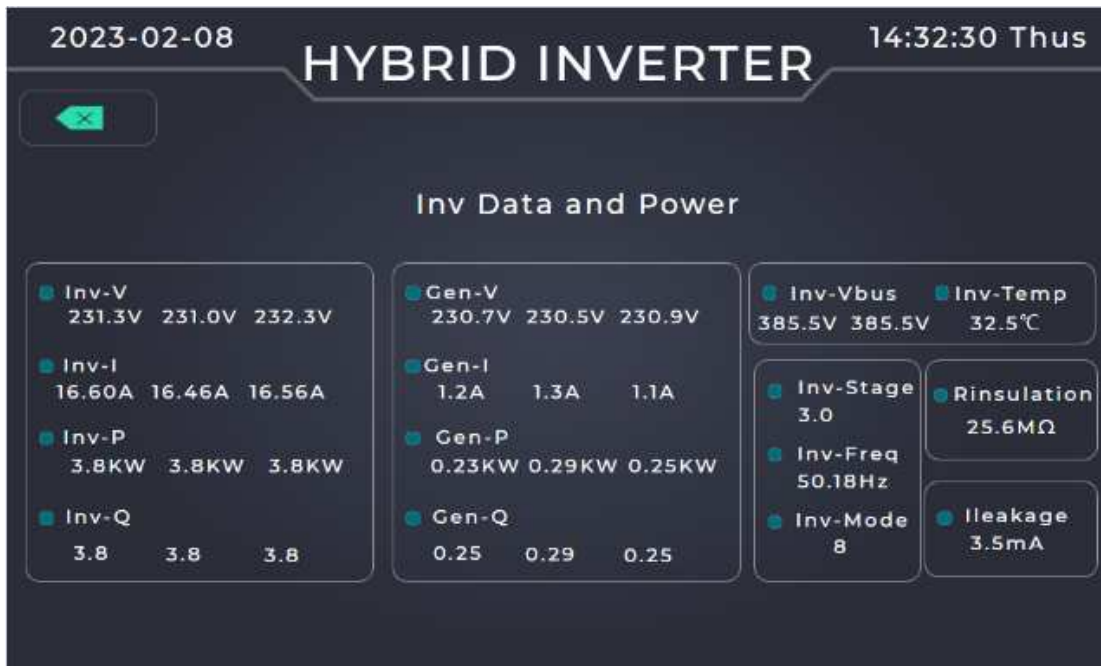

Figure 3.8 Schematic diagram of inverter operation data

Table 3.3 INV-Stage illustrate

Stage	Number	Illustrate
INV Stage	102~129	Protect shutdown
	101	
	201	Shutdown
	231	
	90	Wait for DC to power on
	89	Standby
	30	Normal grid-connected operation
	10	Normal off-grid operation

3.1.4 Grid data

Click the grid icon on the main interface to view its annual, monthly, daily, and current electricity statistics, as shown in Figure 3.9 below. Click DEL on this interface to delete all grid electricity statistics. Click the arrow on the right side of the interface to view the data of other dates

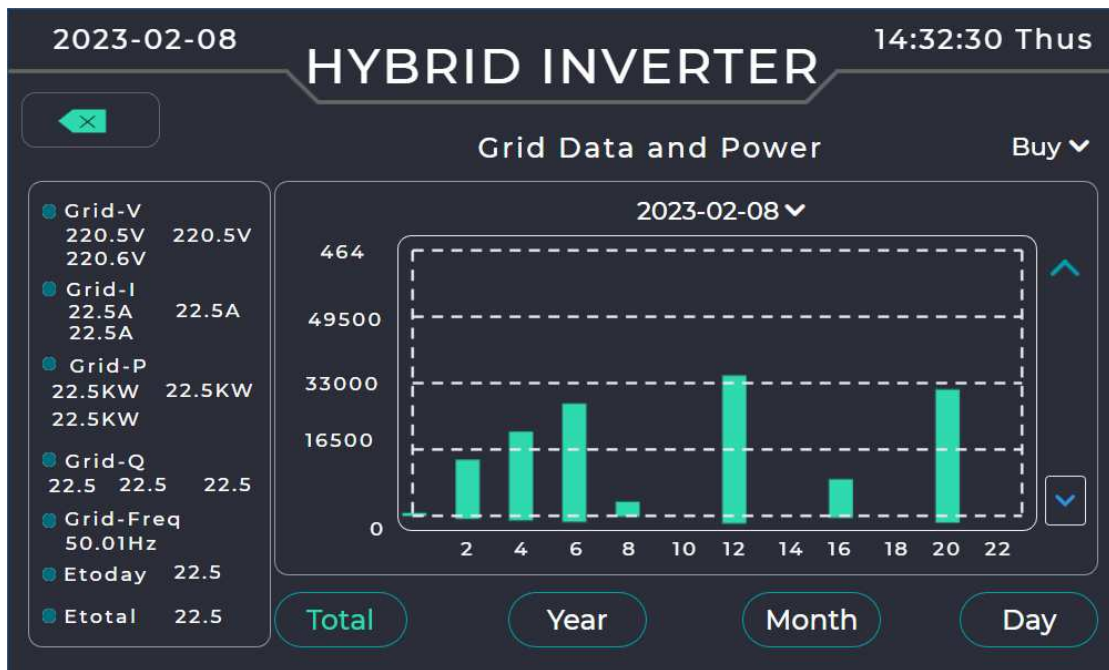

Figure 3.9 Statistics of power grid electricity data

3.1.5 Load data

Click the load icon on the main interface to view its annual, monthly, daily, and current electricity statistics, as shown in Figure 3.10 below. Click DEL on this interface to delete all load power statistics. Click the arrow on the right side of the interface to view the data of other dates.

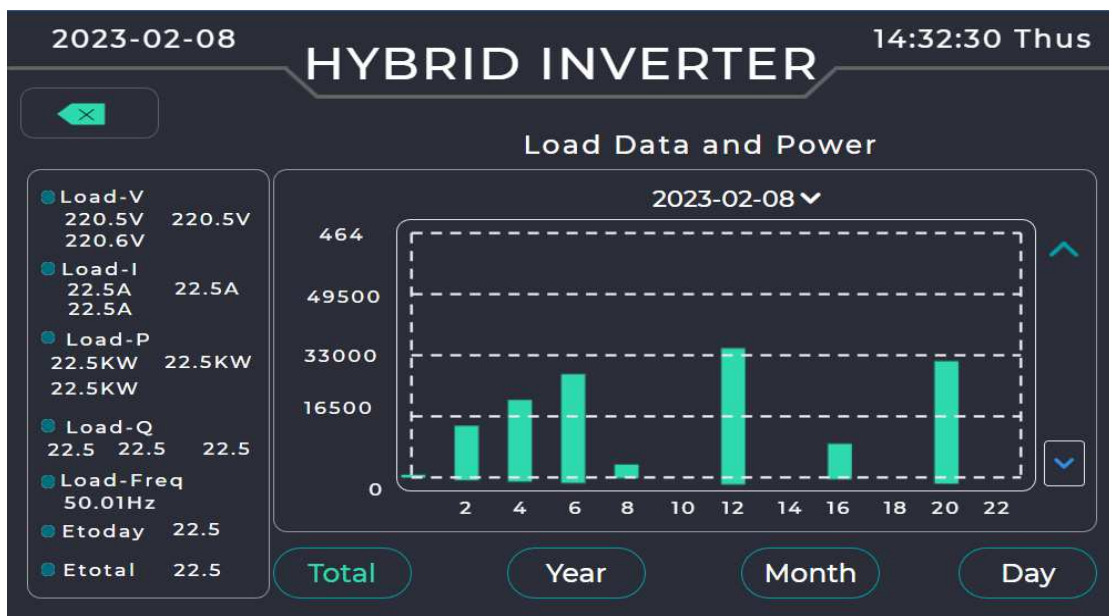

Figure 3.10 Load power data and other statistics

3.2 Run parameter setting

Note again: the password is **750912** when setting the LCD of this device.

Click the "Settings" icon on the main interface to enter the system setting interface, as shown in Figure 3.11, from left to right are "Battery Settings", "Grid Settings", "Professional Settings", and "System Settings".



Figure 3.11 System setting interface

3.2.1 Battery parameter setting

Click "Battery Settings" to set battery-related parameters, as shown in Figure 3.12~Figure 3.14, "Battery Settings1~3", divided into 3 parts.

a. The first part batterySetting1 is the battery setting①: The upper and lower limits of the battery voltage, the upper limit and maximum current of PV1 and PV2 voltage, and the maximum charging and discharging current can be determined.

Bat capacity AH: it tells hybrid inverter to know your battery bank size. "Battery charge and discharge current setting": For AGM and Flooded, we recommend using Ah battery size x 20%= charge/discharge current. For lithium batteries, we recommend Ah battery size x 50%= charge/discharge amps. For GEL lead-acid batteries, follow factory recommendations.

Bat Mode: Select one of "Lithium", "Use Bat V" or "Use Bat %" for all the setting. This will affect ②,③ in that Figure 3.12 and ②,③ in that Figure 3.15 settings below.

b. The second plate is the battery protection setting②

- **Lithium Mode**: This is BMA protocol. Please reference the document Approved Battery .
- **Shutdown**, If the SOC is below this setting, the inverter will shut down.
- **Low Bat**, If the SOC is below this setting, the inverter will alarm.
- **Restart**, The device will resume operation when the SOC reaches the set value and the AC output will resume.
- **TempCorrEn** , When this option is checked, the temperature compensation of the float or average charge in ④ will take effect.

c、The third plate is the three states of battery charging.[③④⑤]:

NO.③ in that figure,3.12,Other battery maintenance settings.Parameters can be set as required.it means:

- **Shutdown**, If the battery voltage is below this setting, the inverter will shut down.
- **Low Bat**, If the battery voltage is below this setting, the inverter will alarm.
- **Restart**, The device will resume operation when the battery voltage reaches the set value and the AC output will resume.

NO.④ in that figure,3.12: According to the setting values of different voltage types in Table 3.1, the default value of temperature compensation coefficient TempCoF/E is -3. Professional installers use, if you do not know, you can choose not to modify the default.

NO.⑤ in that figure,3.12: Professional installers use, if you do not know, you can choose not to modify the default.

Battery Setting2、3: The interface is for power grid and engine power, voltage, upper limit of charging and discharging current, battery operation mode, time curve operation mode, etc. If you are not clear, you can choose default without modification.

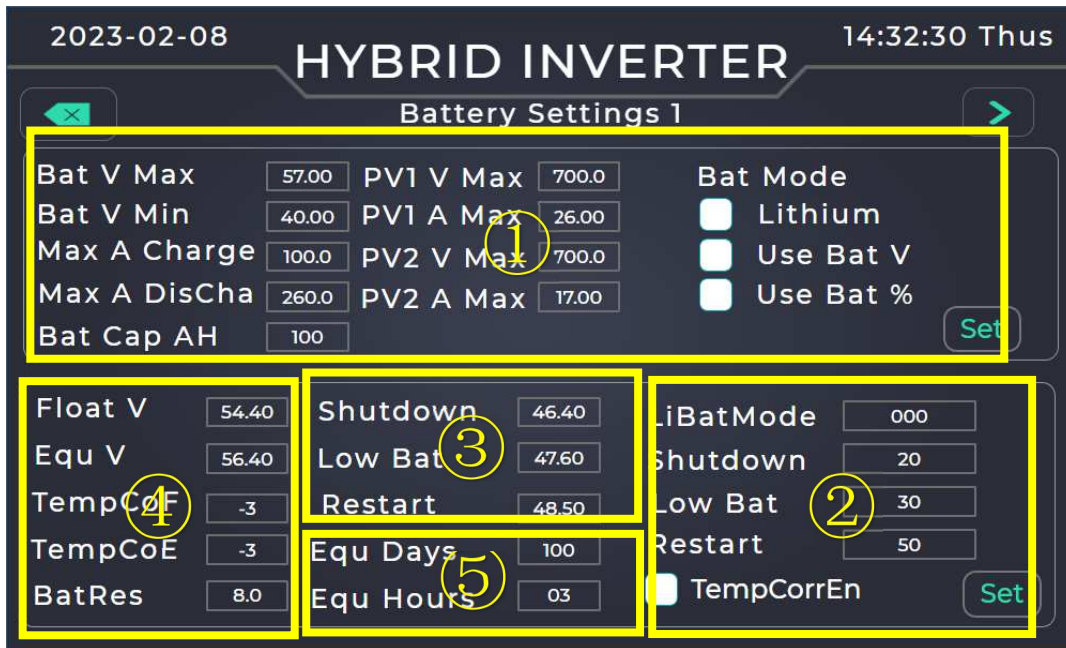

Figure 3.12 Battery Setting 1 Interface

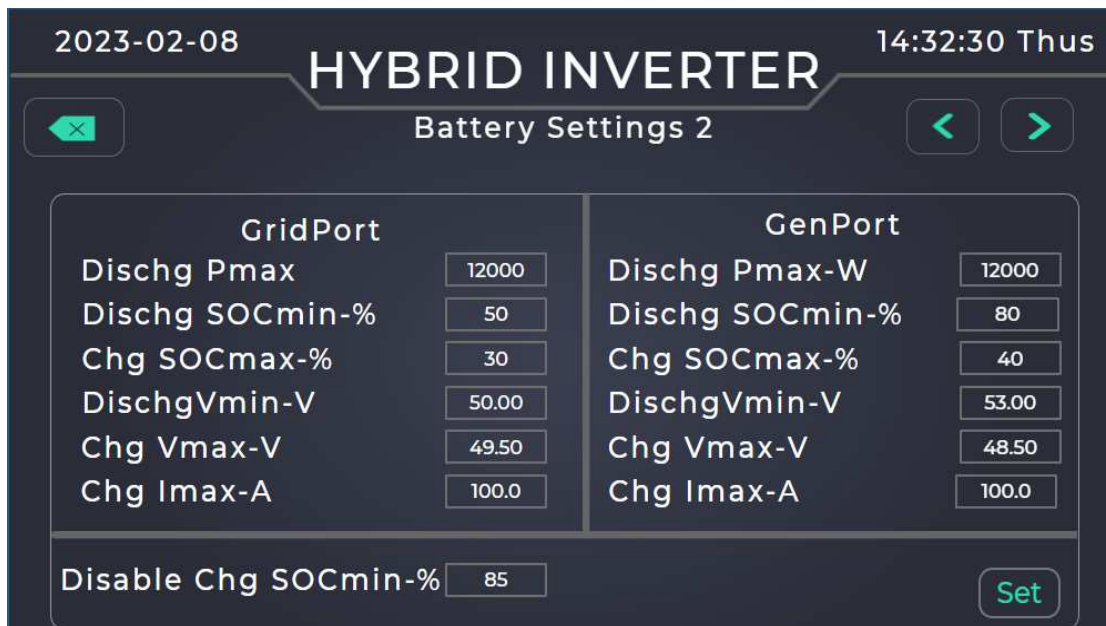

Figure 3.13 Battery Setting 2 Interface

- Dischg SOCmin-%: Battery discharge minimum SOC, battery SOC below this value will not be discharged.
- Chg SOCmax-%: The maximum SOC value of battery charging, above which the battery SOC will no longer be charged with the grid or gen. When “the Disable Chg SOCmin-%” is higher than this value, the PV will continue to be charged to the minimum value of the Disable SOC.
- Disable Chg SOCmin-%: The minimum SOC value of the battery charge, AC and photovoltaic side are no longer charged.

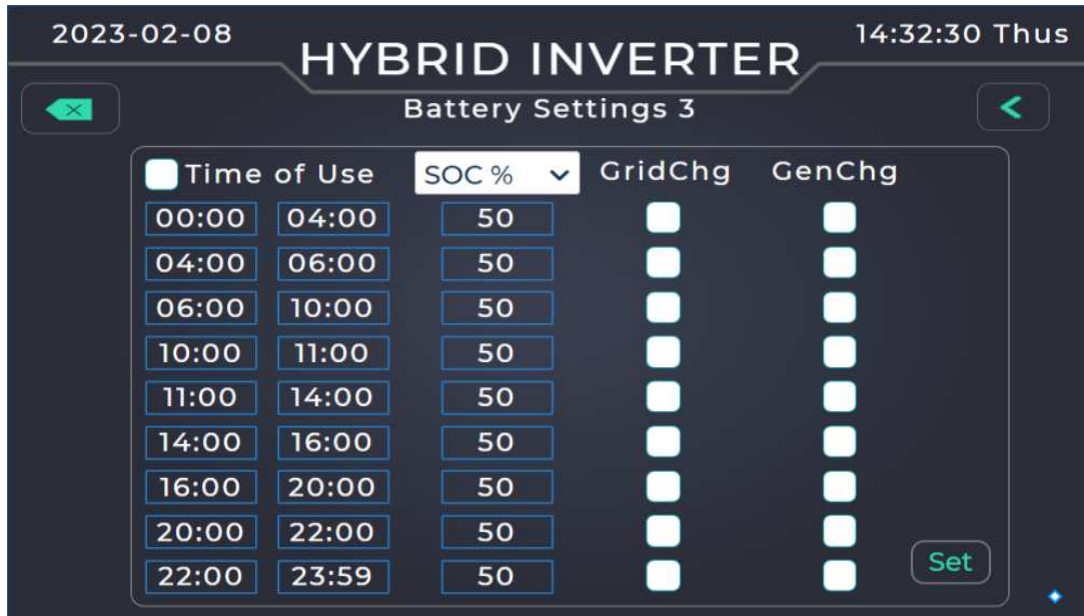

Figure 3.14 Battery Setting 3 Interface

Table 3.1 Recommended settings for different batteries

Battery Type	Absorption stage	Float stage	Torque value Per 3hours per 30 days
AGM or PCC	14.2V 57.6V	14.4V 53.6V	14.2V 57.6V
GEL	14.1V 57.4V	14.4V 54.0V	
WET	14.1V 59V	14.4V 55V	14.7V 59V
LITHIUM	Per their BMS decision		

3.2.2 Grid parameter setting

Click "Grid Setting" to set grid related parameters, as shown in Figure 3.15, including grid standard, upper and lower limits of voltage frequency, upper and lower limits of voltage value, grid frequency, GEN interface type, CT transformation ratio, Grid power limit, Genport function setting, etc.

3.2.3 GEN port function settings

When the GEN port can be connected to the Gen, intelligent load or AC coupling unit grid-connected inverter, it is necessary to change the GEN interface type in the setting to the corresponding type. The setting path is shown in Figure 3.16 below. Click GenPortTypee to select the Gen interface type as Generator, Smart loads or AC Couple. Please select according to the actual wiring.

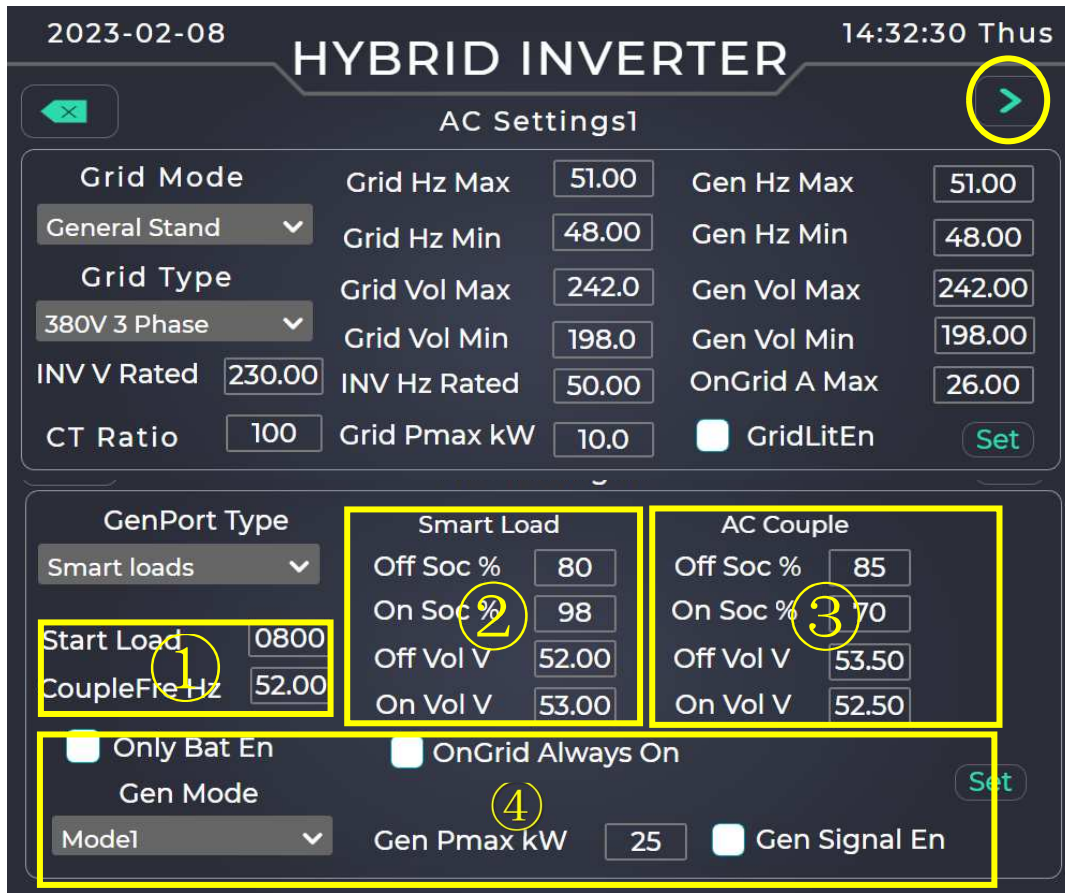

Figure 3.15 Grid Setting Interface

Description of operation logic:

- When selecting the Gen connected to the GEN interface, please confirm that the control line of the Gen is also connected to the J8 terminal NO2&COM2 Gen adjustment control , NO1&COM1 Gen start control , select GenPortTypee as Generator in the grid setting interface in Figure 3.15. At this time, Select Gen Mode, choose one of the two Modes,when the grid is powered off, the diesel generator will automatically start up to supply power to the system.
- When selecting the smart load connected to the GEN interface, select GenPortTypee as Smartloads in the grid setting interface in Figure 3.15, and the Gen relay will be turned on at this time, and the GEN interface will supply power to the smart load for output.

Definition of function settings in number ② in Figure 3.15:

Off Soc%: When the battery SOC% is lower than the set value, the inverter will stop supplying power to the Smart load.

On Soc%: When the battery SOC% is higher than the set value, the

inverter will start supplying power to the Smart load.

Off Vol V: When the battery voltage is lower than the set value, the inverter will stop supplying power to the Smart load.

On Vol V: When the battery voltage is higher than the set value, the inverter will start supplying power to the Smart load.

- When selecting the smart load connected to the GEN interface, select ACCouple as GenPortTypee in the grid setting interface in Figure 3.15, and then ACCouple and the grid supply power to the system together.

Definition of function settings in number ①③④ in Figure 3.15:

StartPower: AC Couple power setting, the maximum power supply value of the AC coupling device.

Couple Fre Hz: AC coupler frequency setting.

Off Soc%: When the battery SOC% is higher than the set value, the AC couple will not participate in the system power supply.

On Soc%: When the battery SOC% is lower than the set value, the AC couple and the inverter are connected to the grid to supply power to the system.

Off Vol V: When the battery voltage is higher than the set value, the AC couple does not participate in the system power supply. .

On Vol V: When the battery voltage is lower than the set value, the AC couple and the inverter are connected to the grid to supply power to the system.

Only Bat En:When the battery is working, the system will always power the Smart Load.

OnGrid Always on:When the inverter is working On grid, the system will always power the Smart Load.

Gen Pmax kW:This value is the maximum power value of the external Gen, and the system will regulate the system according to this value.

Gen Signal En:Output Gen signal control enablement, including power on and off and speed control control.

Gen Mode:According to different Gen, inverter operation mode is different, most equipment choose MODE2, if the main interface does not show that the Gen participates in system operation, please switch MODE1.

3.2.4 CT transformation ratio setting

Click the CT Ratio data box in the grid setting interface in Figure 3.15 to set the CT transformation ratio. When the model of transformer is 100:50mA, the interface value shall be filled with 100. If the transformer is 150:50mA, the value should be 150.

The slave value is very important. The wrong setting will affect the normal operation of the equipment. If you are not sure, please keep the default or contact us.

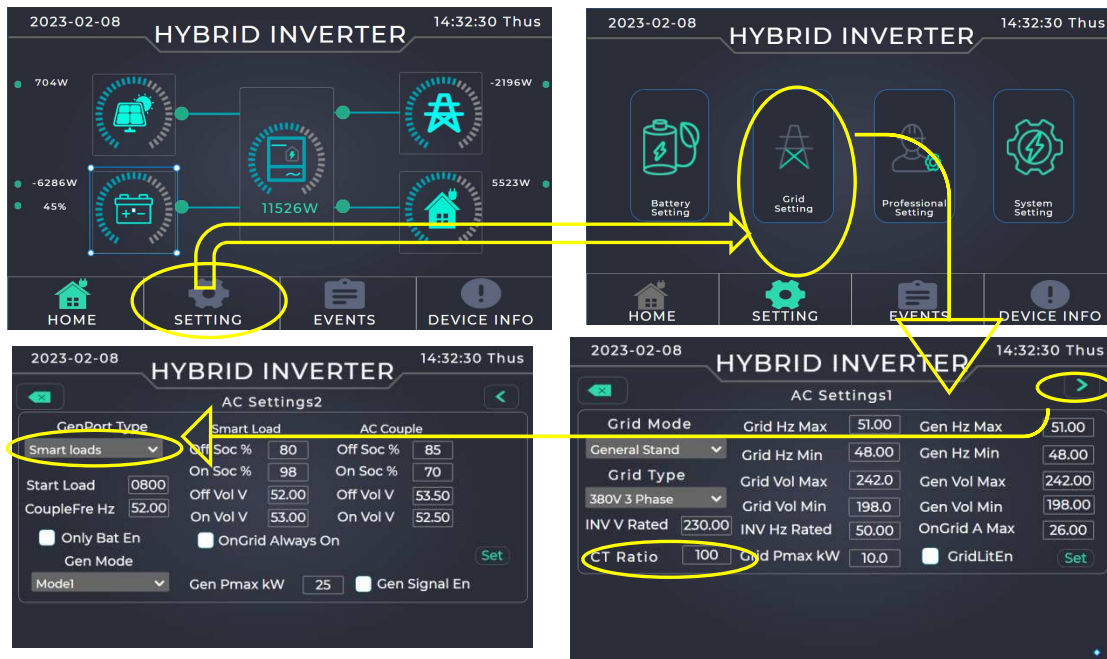

Figure 3.16 Intelligent Load and CT Ratio Setting Path

3.2.5 Operating Mode Settings

Click "Professional Setting" to select equipment operation mode, parallel operation quantity and address during parallel operation, Inv address of each equipment shall be set differently and cannot be repeated, for example, equipment AInv is 1 and equipment BInv can be set to 3, as shown in Figure 3.17. For detailed operation logic, refer to 2.9 Single-machine operation and logic description in Chapter 2

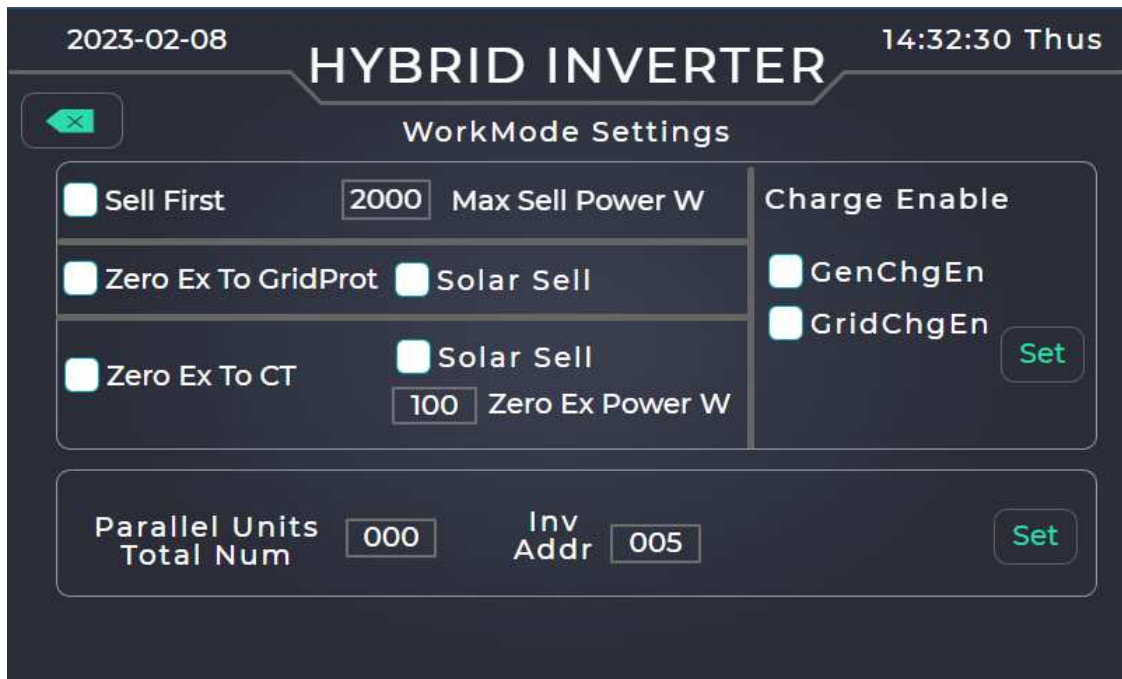

Figure 3.17 Working mode setting interface

3.2.6 System Setup

Click "System Setting" to set relevant parameters of the system, as shown in Figure 3.18, including device time, LCD address, device serial number, read firmware status, BMS address, etc.

Click on the BMS PORT list to select the battery brand you are using.

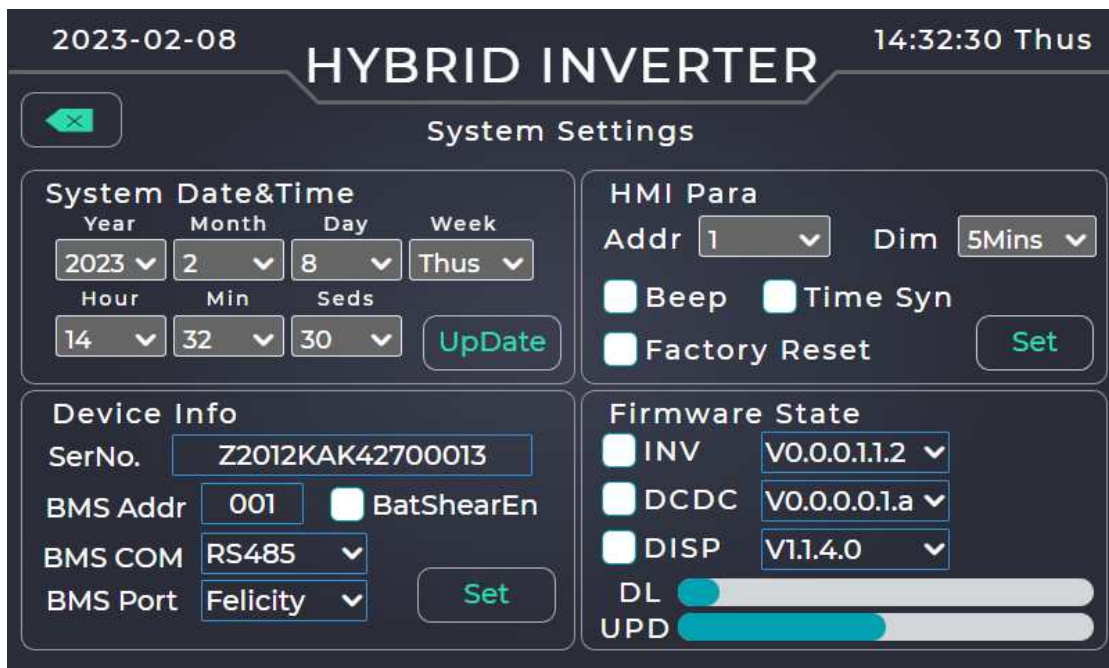

Figure 3.18 System Setting Interface

3.3 Events Display

Click the "History" icon on the main interface to view all the running status and other information of the equipment, as shown in Figure 3.19. When the equipment runs abnormally, you can view this event record. For detailed handling opinions, please refer to "Table 4.2 Equipment Alarm Information and Handling Methods" in Section 4 Operation and Maintenance.

The screenshot shows the 'Events Recorder' interface. It features a table with 10 rows of event records. To the right of the table are controls for page navigation: 'TPage' (419), 'PPage' (1), an up arrow, a down arrow, and a 'Del' button. At the bottom, there is a navigation bar with four icons: HOME, SETTING, EVENTS (highlighted in green), and DEVICE INFO.

Order	Time	Record
1	2023-05-03 12:30:40	PV2 Startup
2	2023-05-03 12:30:40	PV1 Startup
3	2023-05-03 12:30:40	Load Voltage Fault
4	2023-05-03 12:30:40	AC Phase Lock Fault
5	2023-05-03 12:30:40	Load Voltage Fault
6	2023-05-03 12:30:40	PV1 Low Voltage Fault
7	2023-05-03 12:30:40	PV2 Low Voltage Fault
8	2023-05-03 12:30:40	AC Fast Cheak Fault
9	2023-05-03 12:30:40	Voltage Fault of Grid Phase A and Phase B and Phase C
10	2023-05-03 12:30:40	AC Phase Lock Fault

Figure 3.19 Historical Information Interface

3.4 Device Info

Click the "DeviceInfo" icon on the main interface to view the equipment serial number, BMS communication protocol, BMS communication address, INV/DCDC software version, LCD software version HMI and other status information, as shown in Figure 3.20.

Device Infomtion

Order	Term	Version
1	Serial number	Z2012KAK42700013
2	BMS Protocol	Felicity
3	BMS Addr	5
4	BMS Com	RS485
5	INV Software	V0.0.0.1.1.2
6	DCDC Software	V0.0.0.0.1.a
7	Dis Software	V1.1.4.0
8	Protocol	V1.0.0.5
9	WIFI Firmware	V1.0.0.3

HOME

SETTING

EVENTS

DEVICE INFO

Figure 3.20 Equipment Information Interface

4 Operation and maintenance

4.1 Trial run

When the equipment and other device cables such as batteries are properly installed and connected, simply press the on/off button round button on the right side of the enclosure to turn on the device. When the system is not connected to the battery, but connected to the PV or grid, and the ON/OFF button is off, the LCD will still light up the display will show OFF, in this case, the system can still work without selecting "BatMode" when the ON/OFF button is turned on. To specify the relevant mode, please go to the equipment working mode as shown in Figure 3.16. The definition of LED flashing signal and LCD key is shown in Table 4.1 below.

The definitions of LED flashing signal and LCD key are shown in Table 4.1 below. Press UP and ENTER at the same time to restart the LCD.

Table 4.1 Definition of LCD keys

	LED definition	Instructions
DC	The green light continues to shine.	PV connection normal
AC	The green light continues to shine.	Power grid connection normal
Normal	The green light continues to shine.	Normal inverter operation
Alarm	Red light flashing	Fault or warning
ESC		Exit setting
UP		Go to the previous option
DOWN		Go to the next option
ENTER		ENTER certainty

4.2 Fault alarm and handling

If the device fails to start, click the Events icon on the home screen to view historical alarms and rectify faults one by one. Through the analysis of the above methods, determine the cause of the fault, and then determine the appropriate solution according to the field conditions. Table 4.2 lists the device alarm information and handling methods.

- Periodically check whether the wiring of each part of the inverter is

firm and loose, especially carefully check the fan, power module, input terminal, output terminal, and grounding.

- Once the alarm stops, do not start immediately, should find out the cause and repair the restart, check should be strictly in accordance with the inverter maintenance manual prescribed steps.
- Operators must be specially trained to identify the causes of general failures and be able to troubleshoot them, such as skilfully replacing fuses, components and damaged circuit boards. Personnel without training are not allowed to operate the equipment.
- If there is an accident that is not easy to exclude or the cause of the accident is unclear, a detailed record of the accident should be made and the inverter manufacturer should be notified in time for solution.

Table 4.2 Device alarm information and handling methods

Number	Warning	Handling Suggestions
1	AC Self-Checking Fault	1. Check the wiring of the equipment and restart after errors. 2. If the restart failed and reported the error again, please contact us
2	AC Phase Lock Fault	1. Check the wiring of the equipment and restart after errors. 2. If the restart failed and reported the error again, please contact us
3	AC Over Current Fault of Software	1. Please check whether the backup load power is within the range. 2. Restart and check whether it is normal. 3. Seek help from us, if you cannot return to normal.
4	AC Over Current Fault of Hardware	1. Please check whether the backup load power is within the range. 2. Restart and check whether it is normal. 3. Seek help from us, if you cannot return to normal.
5	Load Voltage Fault	1. Check whether the load line wiring is correct. 2. Check the range of AC voltage. 3. Restart the equipment, please contact us if you still fail
6	Grid relay closing power supply	The equipment records this event
7	Inverter voltage source power supply	The equipment records this event
8	The inverter current source is powered	The equipment records this event

9	The Gen relay is closed for power supply	The equipment records this event
10	The battery enters the operating phase	The equipment records this event
11	DC boot complete	The equipment records this event
12	PV1/PV2 is operating normally	The equipment records this event
13	AC Fast Check Fault	1. Check AC, PV, BAT, GEN wiring without error and restart the device. 2. Failure to restart and alarm again, please contact us
14	Buck software overcurrent	1. Check the PV and BAT current range values in the equipment system settings. 2. After disconnect AC, PV, BAT all the power switches, wait 2 minutes and restore the power restart equipment after 2 minutes if it fails to start, try 2 ~ 3 times . 3. If the restart failed and alarmed again, please contact us
15	Battery hardware overcurrent	1. Check the battery current limit value in the equipment system. 2. Check whether the PV and battery wiring of the equipment are normal. 3. Disgle all the power supply and wait for 2 minutes to restore the power to turn on the power. Please disconnect the carrier breakfast first when booting. 4. If the restart failed and alarmed again, please contact us
16	Battery software overcurrent	1. Check the battery current limit value in the equipment system. 2. Check whether the PV and battery wiring of the equipment are normal. 3. Disgle all the power supply and wait for 2 minutes to restore the power to turn on the power. Please disconnect the carrier breakfast first when booting. 4. If the restart failed and alarmed again, please contact us .
17	Battery overvoltage	1. Check whether the battery voltage is too high. 2. Please check whether the upper limit of the battery voltage range in the equipment system is too low. Generally, the highest battery voltage setting value is between 15 ~ 60 V. 3. Please contact us or battery suppliers if you are alert again.
18	Battery undervoltage	1. Check whether the battery voltage is too low. 2. Please check the range of the battery voltage range in the equipment system to check whether the lower limit of the reactor protection parameters is too high. Generally, the minimum battery voltage setting value is between 10 ~ 55 V. 3. Please contact us or battery suppliers if you are alert again.
19	Voltage Fault of Grid Phase C	1. The output voltage is not within the range of the device, and it may be caused by the device stop.

		2. Check the device wiring and the equipment of each power supply normally. restart the device. 3. If you still alert, please contact us
20	Voltage Fault of Grid Phase B	1. The output voltage is not within the equipment setting range, and it may be caused by the device stop. 2. Check the device wiring and the equipment of each power supply normally. restart the device. 3. If you still alert, please contact us
21	Voltage Fault of Grid Phase A	1. The output voltage is not within the equipment setting range, and it may be caused by the device stop. 2. Check the device wiring and the equipment of each power supply normally. restart the device. 3. If you still alert, please contact us
22	PV1/PV2 overvoltage	1. Please check the PV voltage range in the equipment system settings. Generally, the PV voltage setting value is between 160 ~ 800 V. 2. Please contact us or PV supplier again.
24	PV1/PV2 software overcurrent	1. Please check the upload of the PV current in the equipment system settings. 2. Or may there be power fluctuations, disconnect all the power supply and wait for 2 minutes to restore the power supply. If the restart fails and alarm again, please contact us.
25	PV1/PV2 Low Voltage Fault	1. Please check the PV voltage range in the equipment system settings. Generally, the PV voltage setting value is between 160 ~ 800 V. 2. Please contact us or PV supplier again.
26	PV1/PV2 hardware current limiting	1. Please check the upload of the PV current in the equipment system settings. 2. Or may there be power fluctuations, disconnect all the power supply and wait for 2 minutes to restore the power supply. If the restart fails and alarm again, please contact us.

4.3 Product routine maintenance suggestions



◆ Ensure that all the switches on the DC side and AC side of the energy storage controller, battery components, and AC power distribution cabinet are turned off.

◆ After the AC/DC switch of the energy storage converter is turned off, some components of the energy storage controller still have residual voltage. Please wait at least 5 minutes before maintaining the energy storage converter to prevent electric shock!

4.3.1 Routine inspection

- Check whether the temperature of each circuit breaker of the inverter is too high during the daily peak load generally not more than 90°C .
- Check whether the ambient temperature of the inverter is too high for example, ventilate and dissipate the inverter when the temperature is too high .
- The values of inverter, box transformer voltage, current and power are compared during daily peak load.
- Daily check whether the inverter sound is normal.
- Check fault records daily to see if new faults occur.

4.3.2 Monthly inspection

- Check the wiring of each part of the inverter regularly every month, whether it is firm, whether it is loose, and check whether the fan, power module, and terminal block are burned or heated.
- When the inverter needs to be started and stopped, strictly follow the instructions provided by the manufacturer.
- Operators through professional training, no violations of rules and regulations.

4.3.3 Quarterly inspection

- Tighten the screws on the AC and DC sides of the inverter every six months.
- Dust the inverter once every three months.
- In hot weather, open the inverter room vent for ventilation and heat dissipation.

5 Product transportation and storage

5.1 Product Shipping Requirements

5.1.1 Logistics

- The company's inverter is delivered by a professional logistics company, and the logistics company will communicate with the dealer before delivery. Pay attention to accurately grasp the location and contact person of the delivery point, plan the delivery route, and preferably have an alternate route.
- The logistics drivers are very professional. No alcohol, drugs, or phone calls are allowed during driving. The drivers will stop to contact the distributor and consignee before arriving at the destination. Pay attention to communicating in advance, it is best not to disturb the driver halfway and distract the driving attention.
- The type of transport vehicle must be selected according to the actual road conditions. If it is too large, it may exceed the limit and cannot pass, or an unexpected situation may occur.

5.1.2 Unloading and handling

- You must have a special equipment operation certificate to drive a forklift, and you must pay attention to the inspection, and remember to prohibit unlicensed operation.
- Handlers must be equipped with relevant PPE.
- If there is no delivery point for forklift unloading, the pallet can only be removed on the logistics vehicle, and 4 people cooperate to unload one set each time.

5.2 Product storage environment requirements

If the inverter is not put into use immediately, it must be stored as required.

- Pack the inverter in its original packaging, retain the desiccant, and seal it with tape.
- The storage temperature should be kept at $-40^{\circ}\text{C} \sim +70^{\circ}\text{C}$. the relative humidity should be kept at 5%RH~95%RH.
- Store in a clean and dry place, and prevent the erosion of dust and

water vapor.

- Inverters with an outer packaging size of 740*610*390 width×height×depth can be stacked up to 4 layers. When stacking, please place the inverter carefully to avoid personal injury or equipment damage caused by the equipment falling over. Please place it upward first, and it is forbidden to invert it.
- Periodic inspection is required during storage. If insects and rats are found to bite, the packaging materials need to be replaced in time.
- After long-term storage, the inverter needs to be inspected and tested by professionals before it can be put into use.

6 Legal Notices

In addition to the above product warranty, national and local laws and regulations govern the power connection of the product including breach of implied terms and warranties . The company hereby declares that all liability to a limited extent cannot and can only be legally excluded by these terms and conditions, products and warranties.

7 Attachments

Network port definition description

Pin tags	1	2	3	4	5	6	7	8	
J5	RS485B3	RS485A3	NC	CANH	CANL	NC	RS485A3	RS485B3	
Definition	BMS-485 communication			BMS-CAN communication			BMS-485 communication		
J1	CANH1	CANL1	SNY-01	SNY-02	ISOGND1	ISOGND1	CAN-SMH	CAN-SML	
Definition	Parallel synchronous communication								
J2	CANH1	CANL1	SNY-01	SNY-02	ISOGND1	ISOGND1	CAN-SMH	CAN-SML	
Definition	Parallel synchronous communication								
J3	RS485B1	RS485A1	NC	NC	NC	NC	RS485A1	RS485B1	
Definition	Meter communication						Meter communication		
J4	RS485B4	RS485A4	NC	RS485A4	RS485B4	NC	RS485A4	RS485B4	
Definition	Background monitoring			Reserve background monitoring communications			Background monitoring		

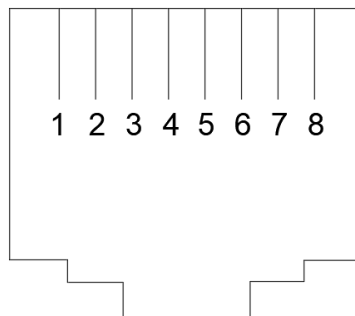
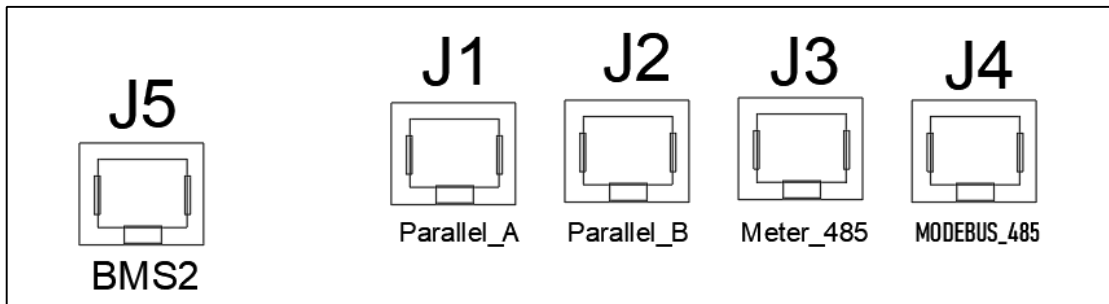

Transformer size and model

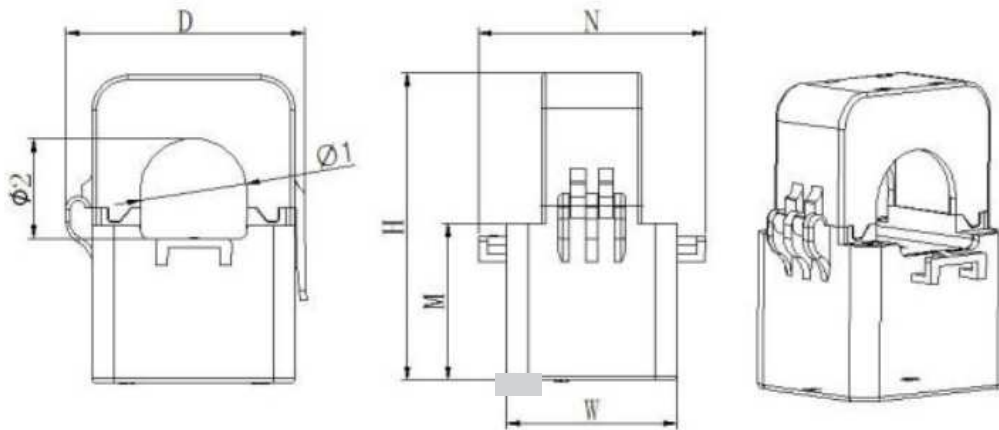

Size Specifications	Overall dimensions mm					Perforation size mm		Tolerance mm
	W	H	D	M	N	Φ1	Φ2	
K-Φ10	27	40	26	24	36	10	9	±1
K-Φ16	31	50	29	28	42	16	17	
K-Φ24	39	71	46	36	52	24	23.5	
K-Φ36	42.5	82	58	40	56	33.5	35	

Hybrid Inverter data

Product type	Mars-10G1-LE	Mars-12G1-LE	Mars-14G1-LE
Battery Input Data			
Battery Type	Lead-acid or Li-Ion		
Battery Voltage Range	40~60V		
Max. Charging Current	220A	250A	280A
Max. Discharging Current	220A	250A	280A
Charging Curve	3 Stage/Equalization		
External Temperature Sensor	Yes		
charging Strategy for Li-Ion battery	Self-Adaption to BMS		
PV string Input Data			
Max. DC Input Power	15000W	18000W	20000W
PV Input Voltage	650V(160V~800V)		
MPPT Range	200V~700V		
Start-up Voltage	160V		
PV Input Current	26A+17A		
Max. PV ISC	34A+20A		
No. of MPPT Tracker	2		
No. of String Per MPPT Tracker	2+1		
AC Output Data			
Rated AC Output Power and UPS Power	10000W	12000W	14000W
Max. AC Output Power	12000	13200W	15400W
Peak Power (off grid)	2 times of rated power, 10S		1.8 times of rated power, 10S
AC Output Rated Current	15.2A/14.5A	18.2A/17.4A	21.1A/20.3A
Max. AC Current	22.7A/21.7A	27.3A/26.1A	27.6A/26.4A
Max. continuous AC Passthrough	50A		
Output Frequency and Voltage	50/60Hz.380/400Vac(Three phase);		
	220/230Vac(single phase)		
Grid Type	Three phase/single phase		
Current Harmonic Distortion	THD<3%(Linear load <1.5%)		
Efficiency			
Max. Efficiency	97.9%		
Euro Efficiency	96.9%		
MPPT Efficiency	99.9%		
Protection			
PV Arc Fault Detection	Integrated (Optional)		
PV Input Lightning Protection	Integrated		
Anti-islanding Protection	Integrated		
PV String Input Reverse Polarity	Integrated		

Protection	
Insulation Resistor Detection	Integrated
Residual Current Monitoring Unit	Integrated
Output Over Current Protection	Integrated
Output Shorted Protection	Integrated
Output Over Voltage Protection	DC Type II/AC Type III
Certification and Standards	
Grid Regulation	CEI 0-21,VDE-AR-N 4105,NRS 097,IEC61727,G99,G98,VDE 0126-1-1,RD 1699,C10-11
EMC/Safety Regulation	IEC/ED 62109-1 IEC/EN 62109-2,IEC/EN 61000-6-1,IEC/EN 61000-6-2, IEC/EN 61000-6-3, IEC/EN 61000-6-4
General Data	
Operating Temperature Range	-45~60°C, >45°C Derating
Cooling	Smart cooling
Noise	≤45dB(A)
Communication with BMS	CAN, RS485
Weight(kg)	44 44 45
Size (mm)WxHxD	550x730x290
Protection Degree	IP65
Installation Style	Wall-mounted
Warranty	5 years

Version No.4.2. 2023.8.30

Zhejiang Chisage New Energy Technology Co., Ltd.

 Tel: +86 150 5749 1826

 Email: info@chisagess.com

 Web: www.chisagess.com

 Add: No.1828, Fuqing South Road, Panhuo Street, Yinzhou District, Ningbo City,
Zhejiang Province, China 315000
